

OPEN JOINT SYSTEM TYPICAL DETAILS

CONTENTS

- 1.0 PLAN - VERTICAL JOINT
- 2.0 SECTION - HORIZONTAL JOINT
- 3.0 SECTION - WINDOW HEAD DETAIL
 - PLAN - WINDOW JAMB DETAIL
- 3.1 SECTION - WINDOW SILL DETAIL
- 3.2 SECTION - SOFFIT JUNCTION
- 3.3 PLAN - WALL JUNCTION
 - SECTION - PIN DETAIL
- 4.0 SECTION - ROOF JUNCTION
- 4.1 PLAN - CORNER DETAIL
- 5.0 SECTION - BASE DETAIL
- 5.1 SECTION - BASE DETAIL

Framing note: Timber framing by others is to be at 600 centers max for both studs & noggs. This may be required at closer centers subject to engineering requirements.

Rigid air barrier note: As per ACMF Branz Appraisal #528 section 12.2 "A building with exposure to wind on any part of its facade above 1.55 kPa ULS must use a RAB as backing for the cavity". It is the building designers responsibility to determine wind loading on the building and incorporate RAB into the detailing as required to the specifications of the RAB manufacturer.

Cavity Battens are not required with the ACMF New Zealand cavity system as a cavity is formed between the fixing angles and structure with high impact plastic packers ("H"packers). Nominal cavity depth is 40mm from structure to outer face of panel. In some situations (when interfacing with residential joinery profiles) this cavity is may be deeper. Any instance where cavity is pushed beyond 60mm may require the installation of 20mm cavity battens by others.

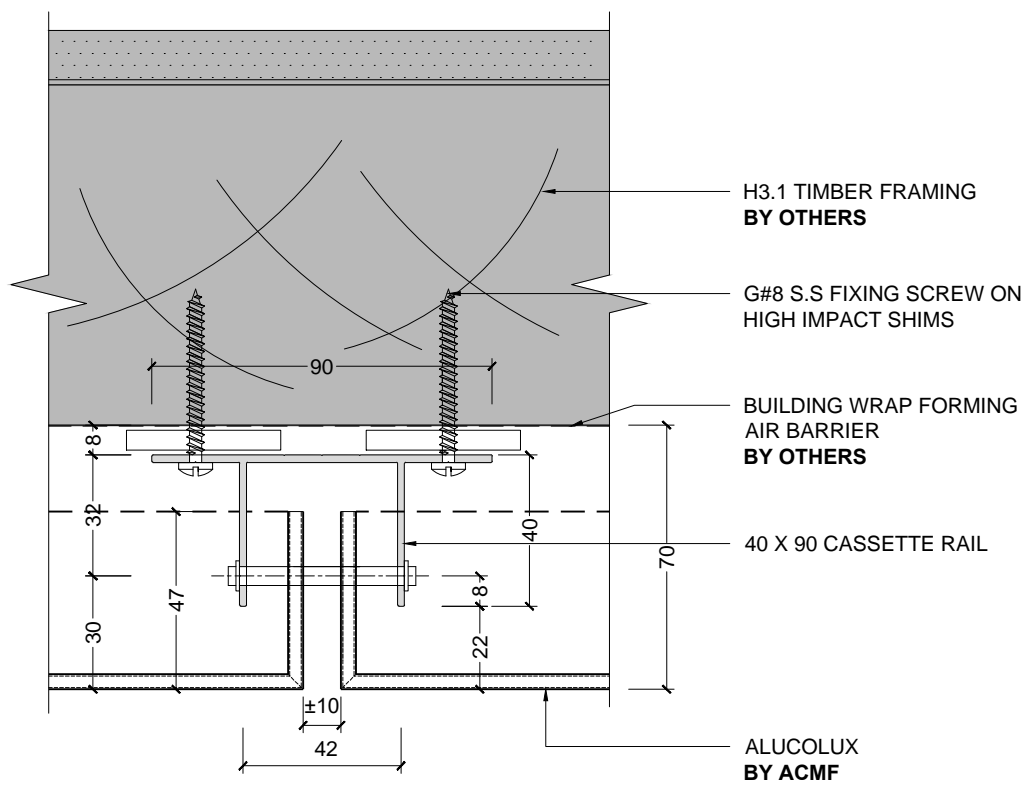

1 PLAN - VERTICAL JOINT

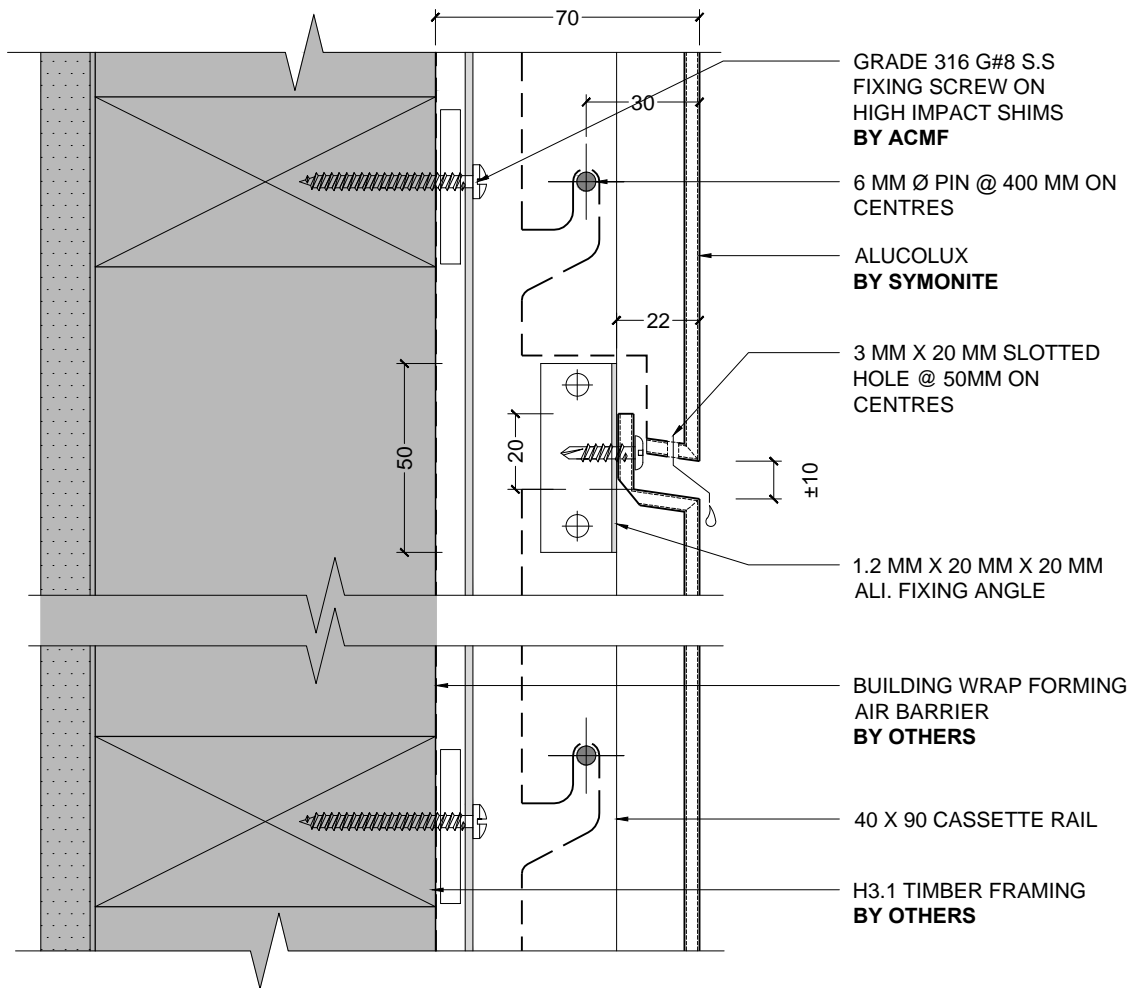

1 SECTION - HORIZONTAL JOINT

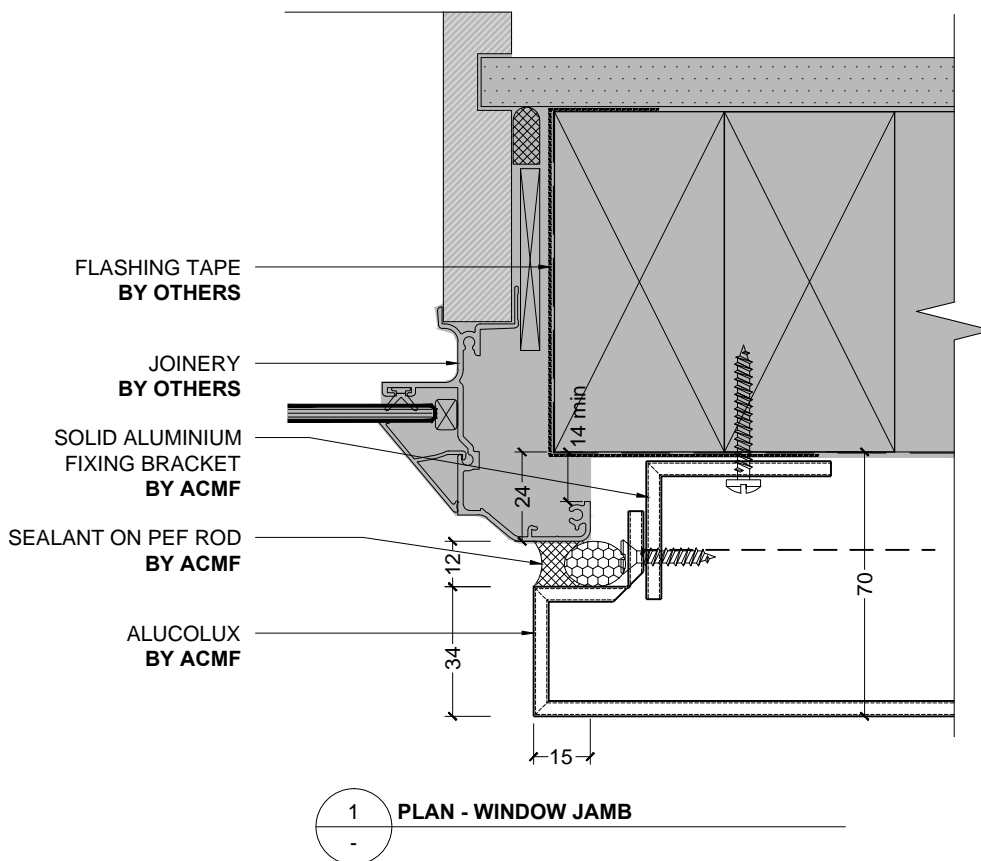
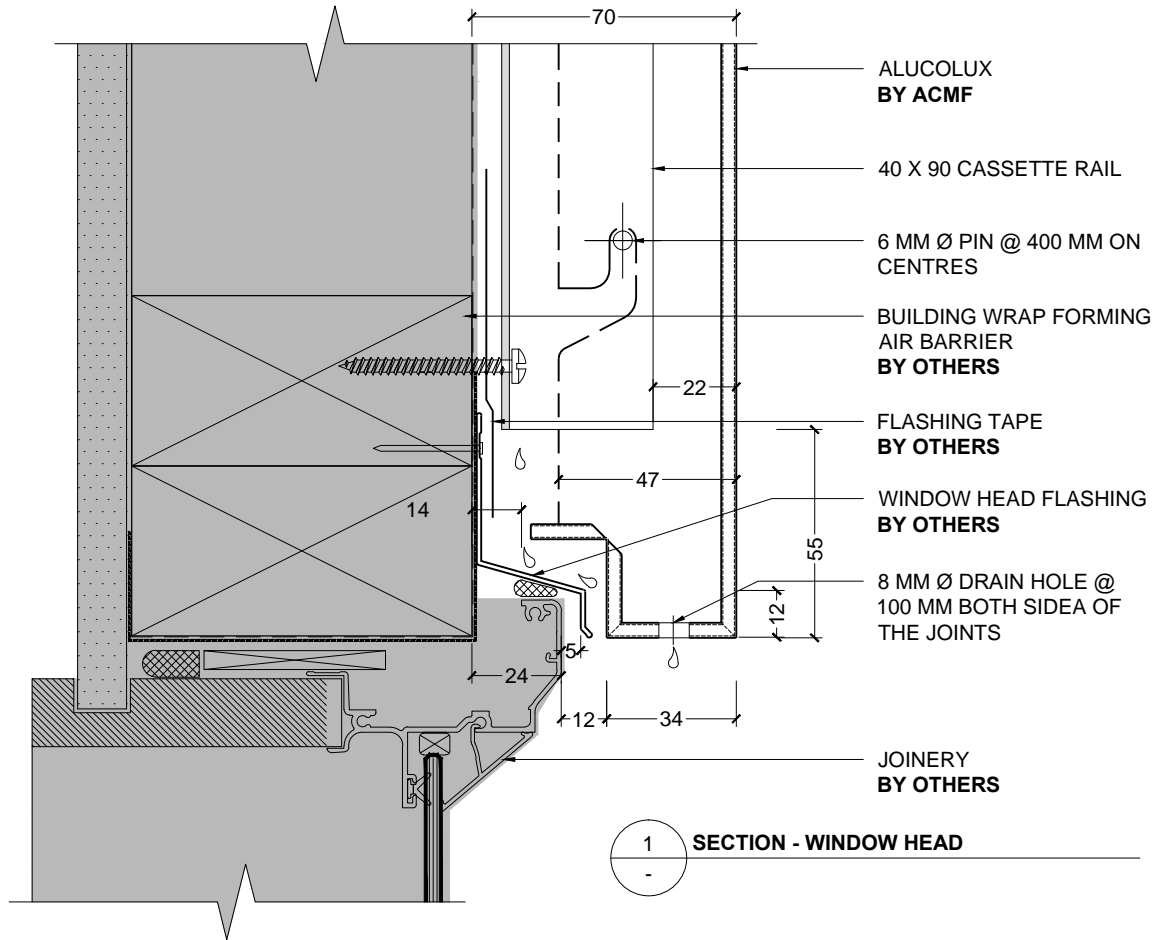

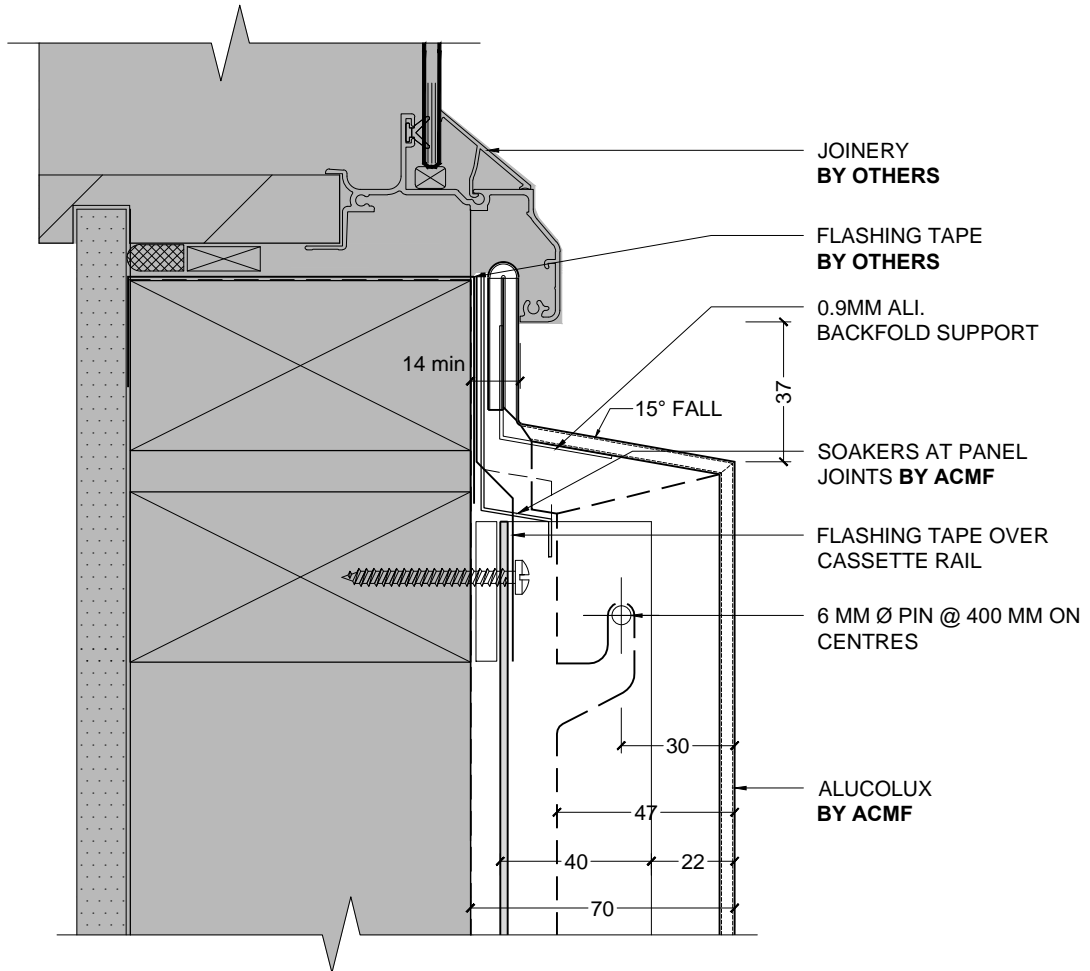

1 SECTION - WINDOW SILL

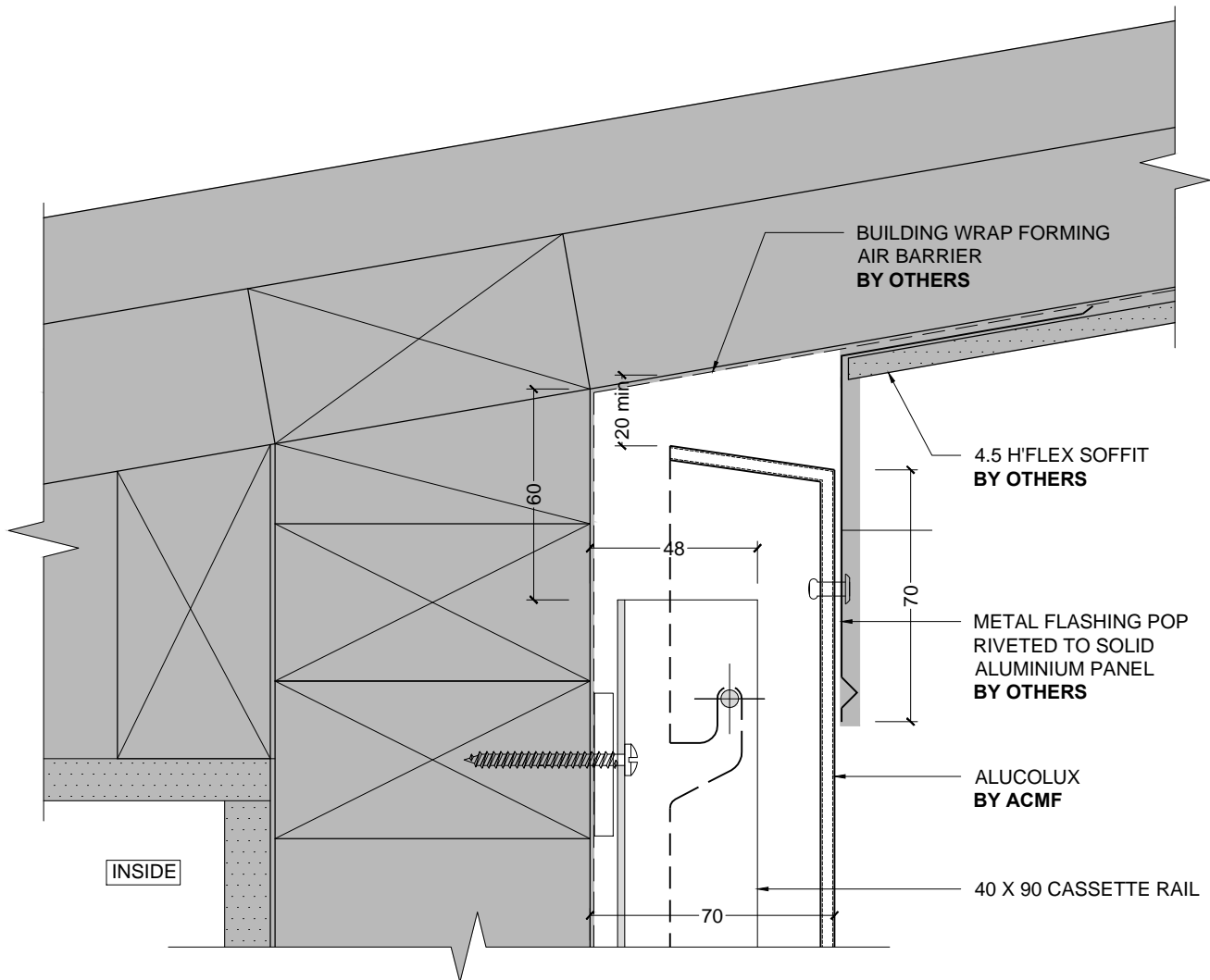

1 SECTION - SOFFIT JUNCTION

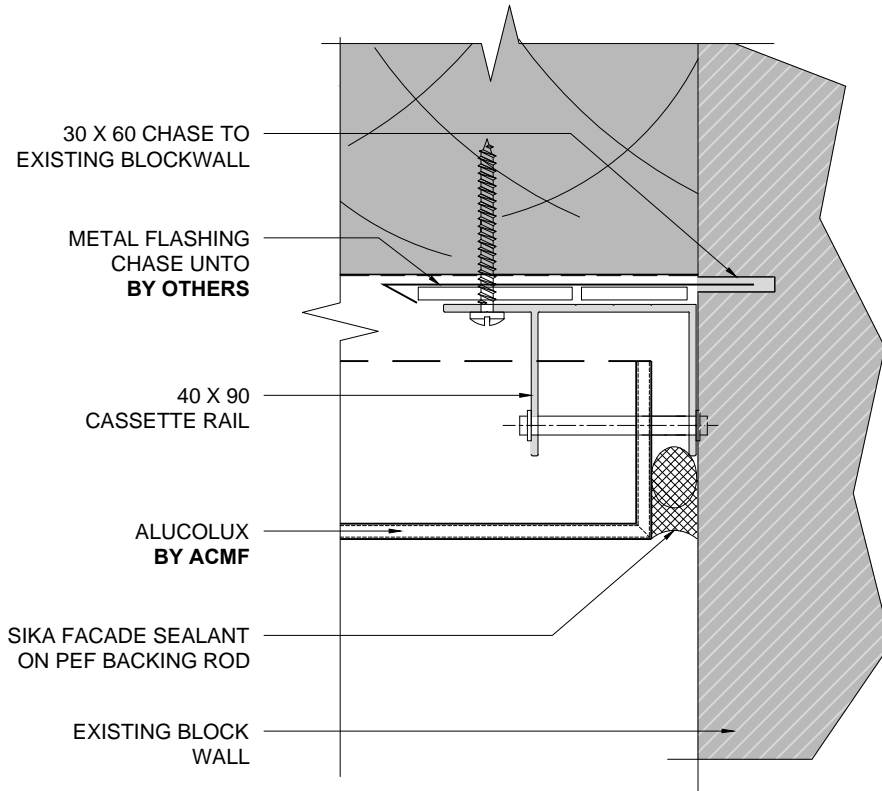

1 PLAN - WALL JUNCTION

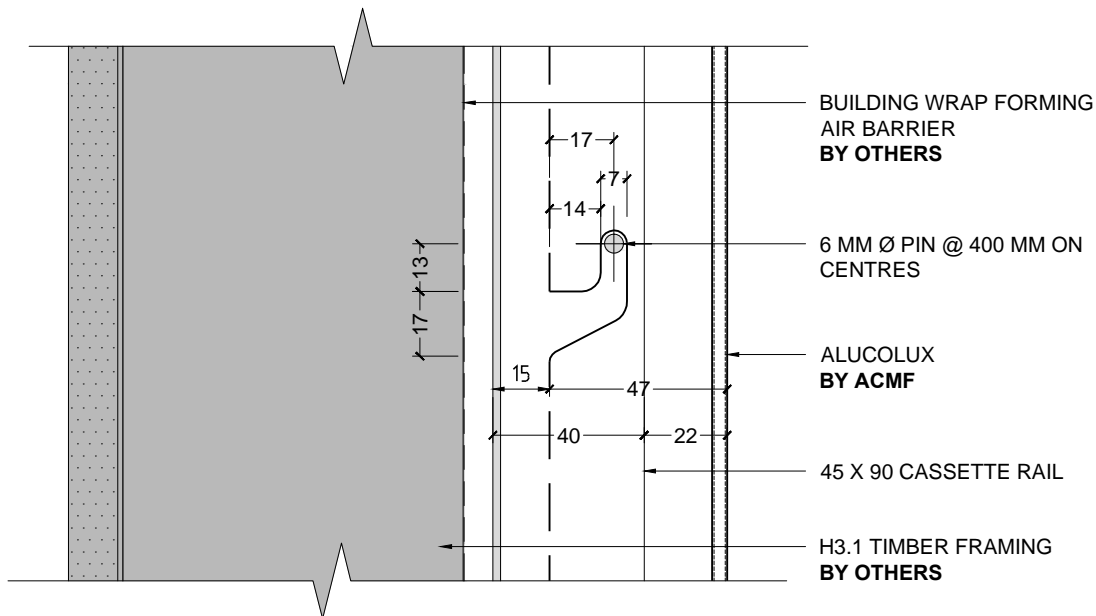

1 SECTION - PIN DETAIL

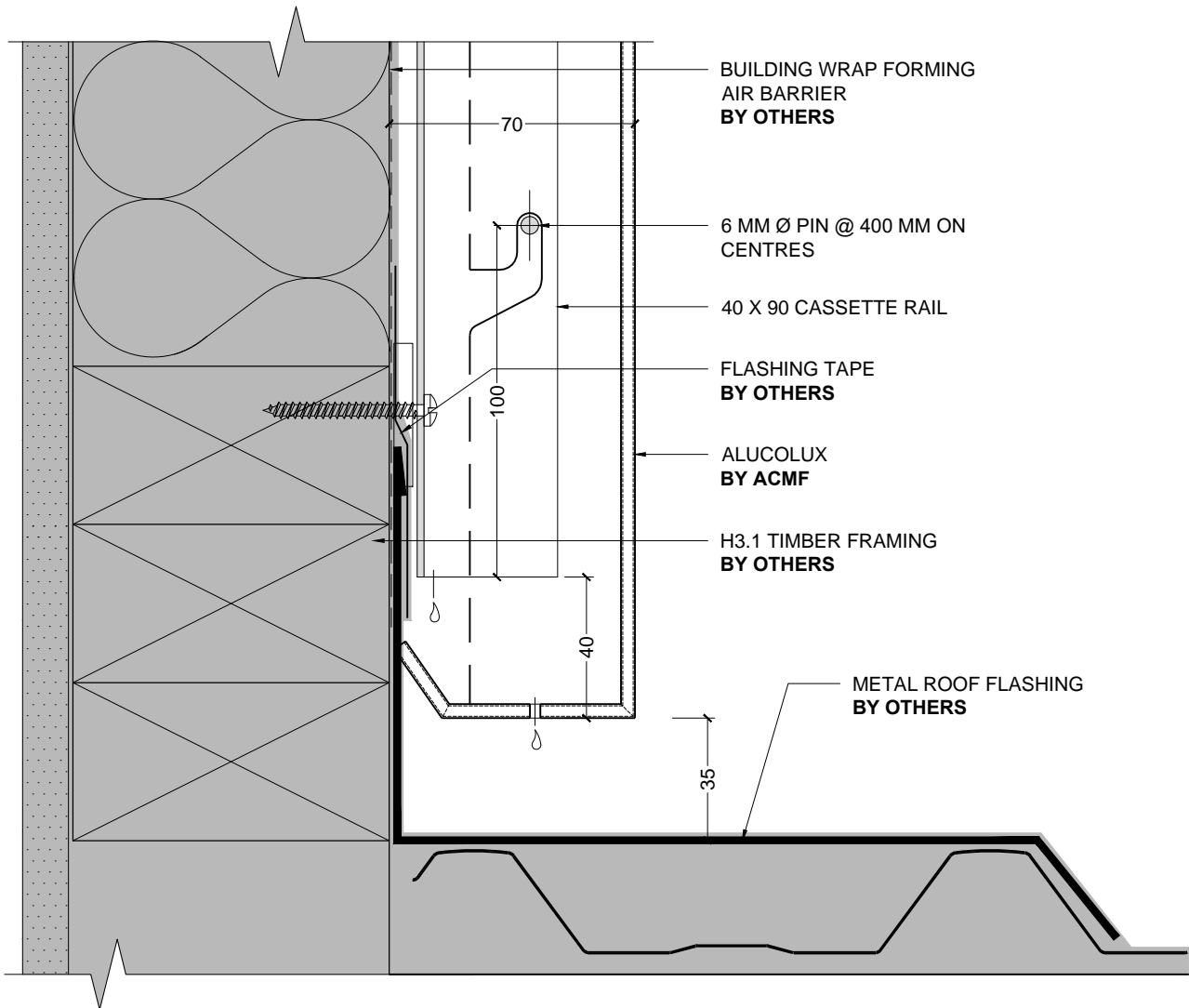

1 SECTION - ROOF JUNCTION

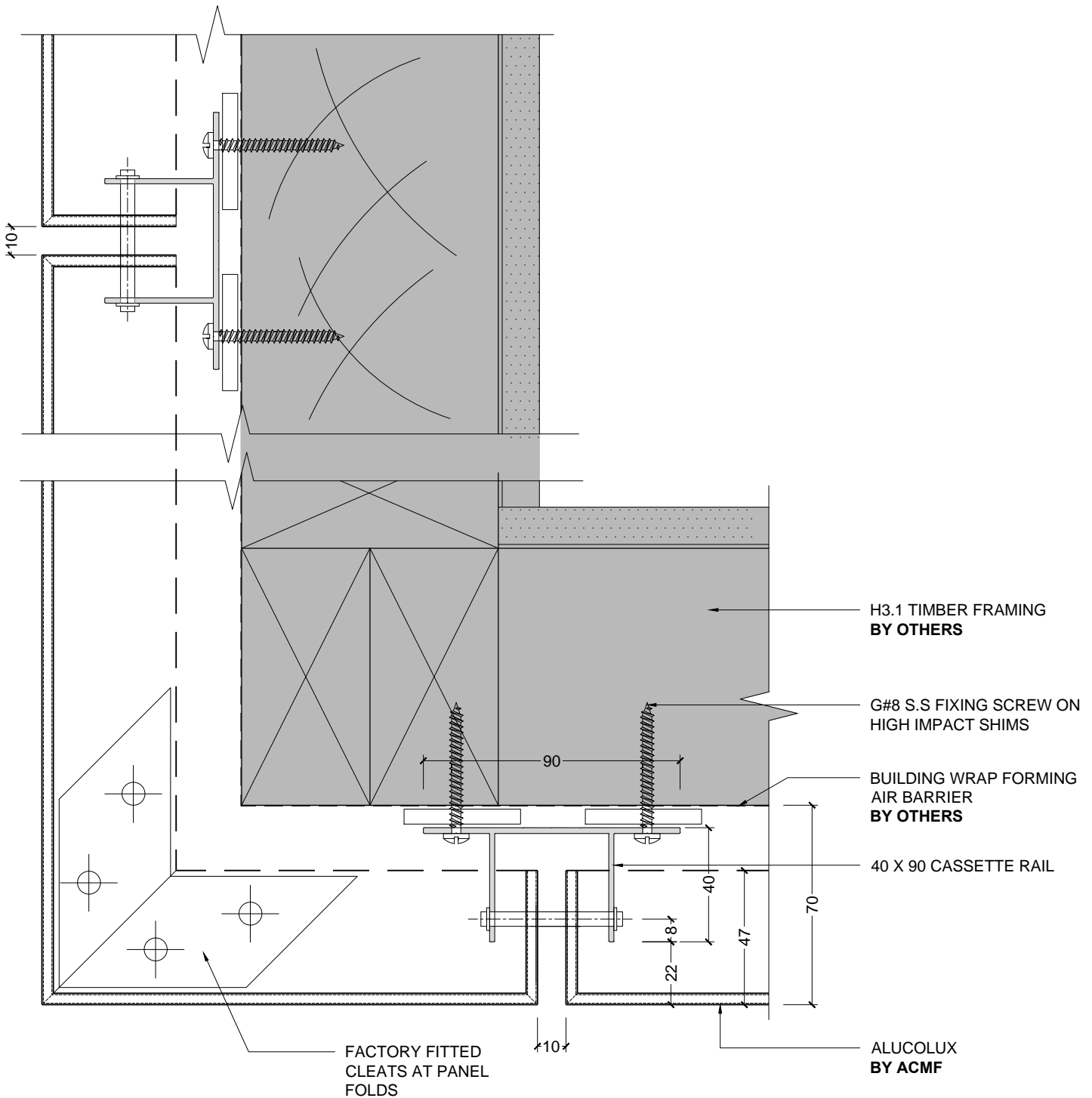

1 PLAN - CORNER DETAIL

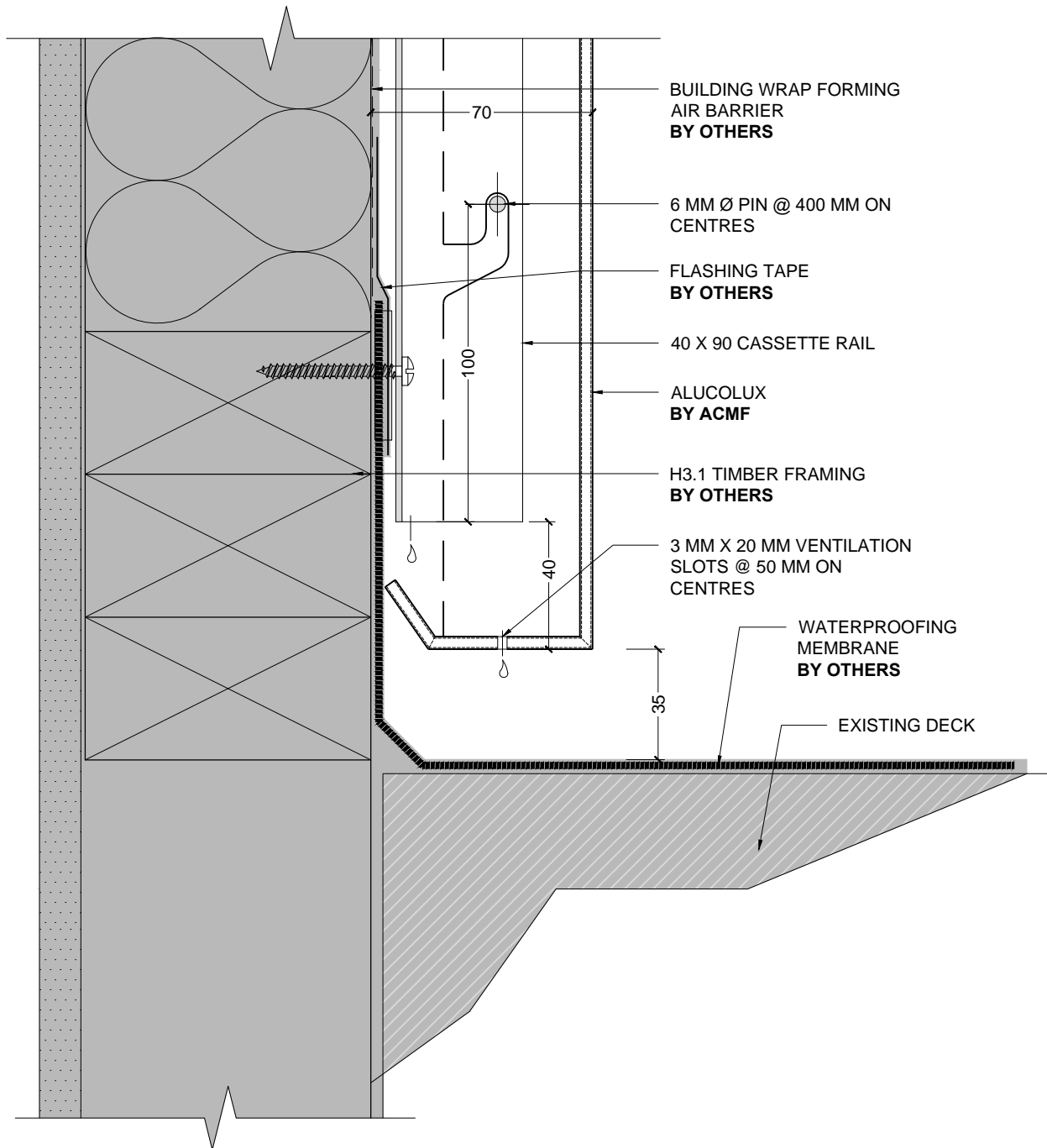

1 SECTION - PANEL BASE

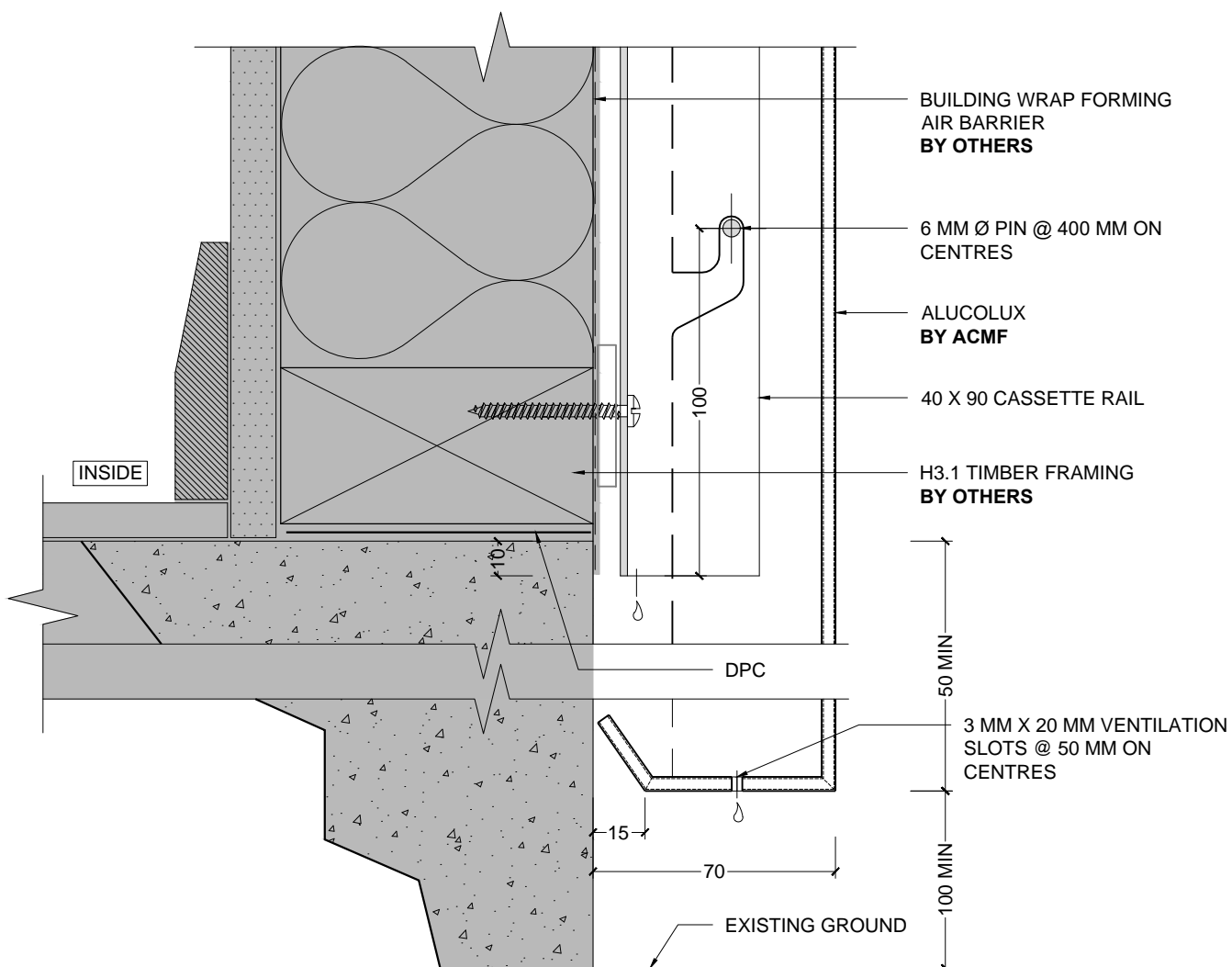

1 SECTION - PANEL BASE