

Terreal Breeze - Terracotta Tile

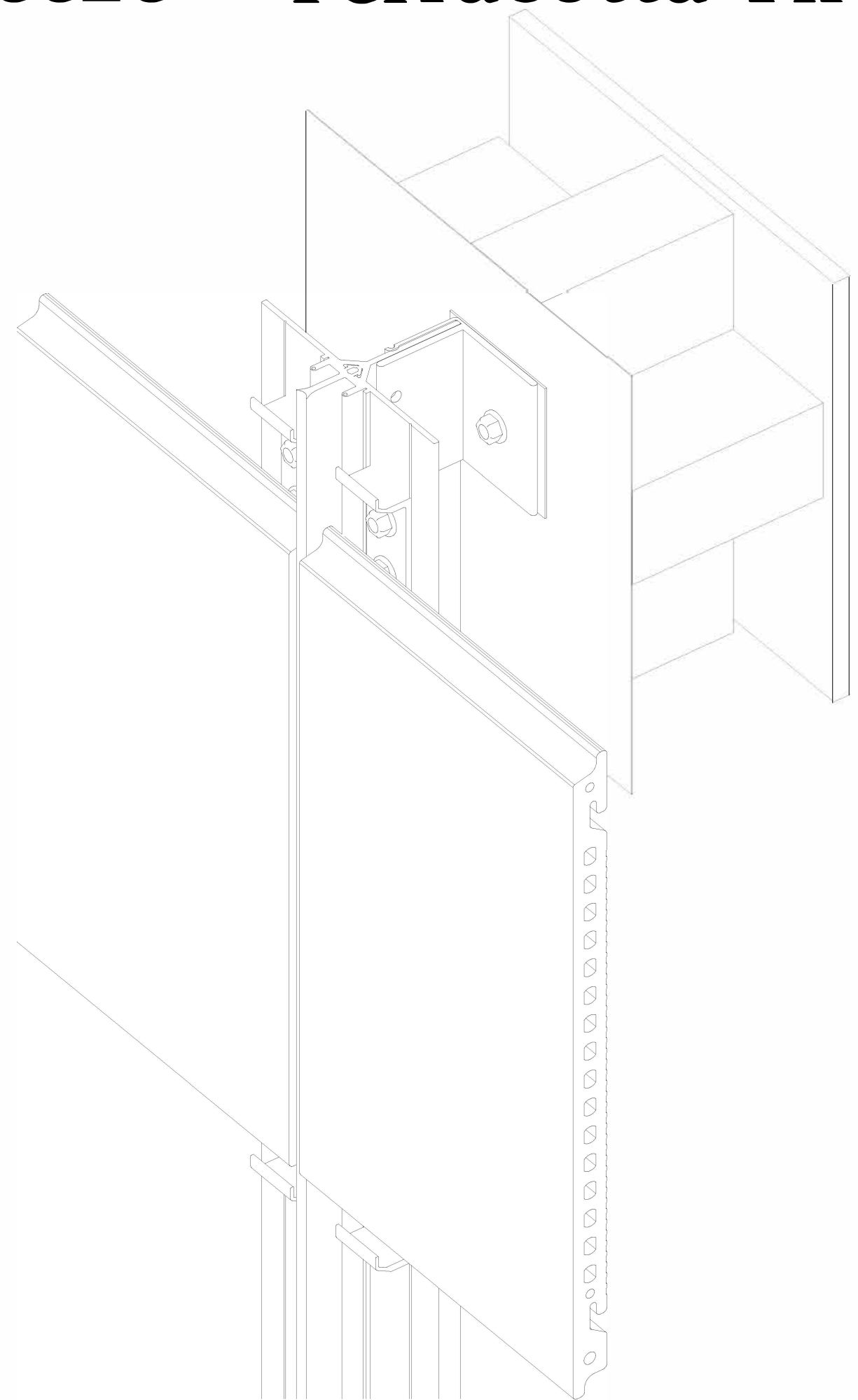

Notes / Spec:

Rev	Date	Notes	By

ACMF
ACM Fabricators Ltd
PO BOX 101 760
NORTH SHORE 0745
TEL: 09 442 5062
454 ELLICE ROAD
GLENFIELD

Copyright - ACM FABRICATORS LTD. No part of this document may be reproduced, stored in a retrieval system in any form or transmitted by any means without prior permission in writing of ACM FABRICATORS LTD. All discrepancies shall be referred to ACM FABRICATORS LTD immediately.

Dwg Title:
Terreal Breeze Terra Cotta Tile

Rev By: EK Chkd: Date: 21.11.14
Scale at A3: 1:2
CAD File: TERREAL BREEZE [DETAIL] R20190122.DWG
CAD Path: Terreal Breeze [Detail] R20190122.dwg

Dwg Revision:
20190122

Dwg No:
01-01- BR+SFA

Key

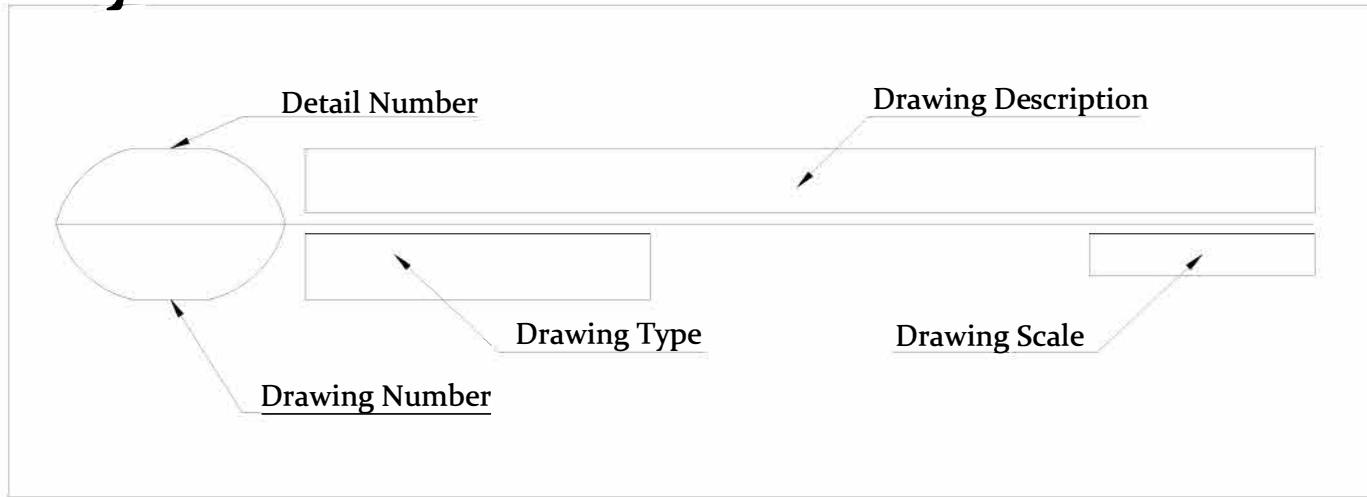

TERREAL Breeze® is an extra slim (16mm) double skin rainscreen cladding system it has small dimensions (30 x 60cm) with overlapping horizontal joints. It offers the advantage of the double skin thermal insulation and moisture protection of the building thanks to its complete closed-wall system and through ventilation. Its format makes it lighter and easier to install and also more cost efficient than other large double skin products. It can be used for new structures as well as for upgrading residential, commercial or industrial buildings.

-NOTE:
 SYMONITE PANELS LTD T50 CLADDING
 SUPPORT SYSTEM INSTALLATION MANUAL
 MUST BE FOLLOWED AT ALL TIMES.
 01-06 T50 Installation Manual Rev. 20150501

-NOTE:
 FOR WRAP FIXING REFER TO SPECIFIED
 MANUFACTURER INSTALLATION MANUAL

- Abbreviations:
 -RWU - Rigid Wall Underlay

Spec. List

1. TIMBER FRAMING
- 2a. RIGID WALL UNDERLAY, FIBRE CEMENT SHEET 6MM
- 2b. BUILDING MEMBRANE
3. TESCON NAIDEC BUTYL STRIP
4. BRACKET T50 BR
- 4a. SELF-DRILLING HEX HEAD SCREW CLASS 4 HDG 12g x 22 mm
5. VERTICAL ALUMINUM SUPPORT T50 VR
- 5a. SELF-DRILLING SS PH 6g X 12 MM
- 8b. TERREAL BREEZE TERRA COTTA TILE, 16MM DOUBLE WALL
9. 14g x 75 mm TIMBER TEK SCREW CLASS 4 HDG / 1 PER BRACKET
- 12a. ALUMINUM Window JOINERY
13. T50 CL ALUMINUM CLIP PROFILE
14. T50 JC ALUMINUM JAMB CLOSER
16. BREEZE C-3 SUPPORT CLIP

Notes / Spec:

Breeze Typical Details

Rev	Date	Notes	By



Copyright - ACM FABRICATORS LTD. No part of this document may be reproduced, stored in a retrieval system in any form or transmitted by any means without prior permission in writing of ACM FABRICATORS LTD. All discrepancies shall be referred to ACM FABRICATORS LTD immediately.

Dwg Title:
 Terreal Breeze Title

Rev By: EK Chkd: Date: 21.11.14
 Scale at A3: 1:2
 CAD File: TERREAL BREEZE [DETAIL] R20190122.DWG
 CAD Path: Terreal Breeze [Detail] R20190122.dwg

Dwg Revision:
 20190122

Dwg No:
 BREEZE TITLE

FIXINGS

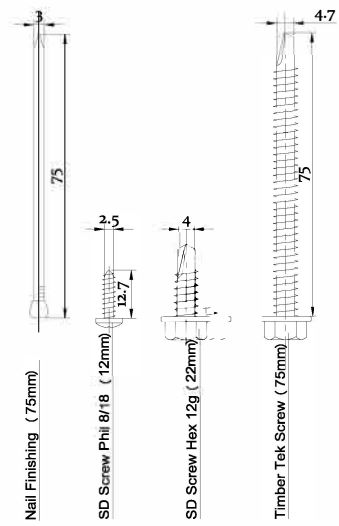

MEMBRANES

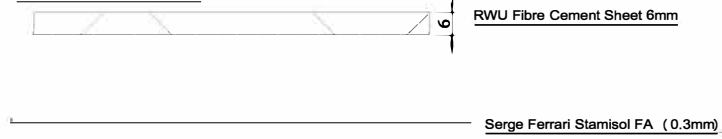

TAPES



TIMBER

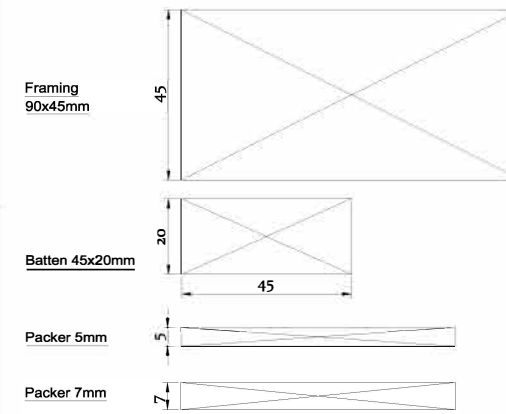

ADHESIVES/SEALANTS

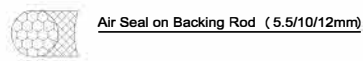

Available Facade Systems

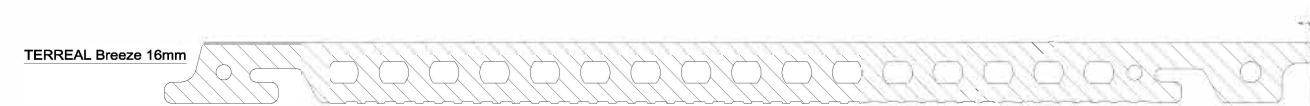

Extrusions

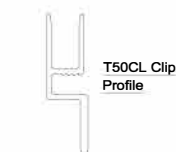

T50BR Support Bracket
Butyl Tape 60mm (0.8mm)

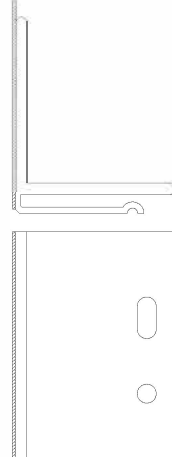

T50JC Jamb
Closer Profile

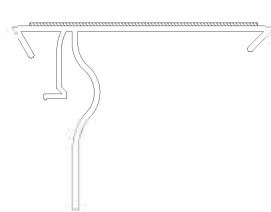

Terreal Vertical T Profile

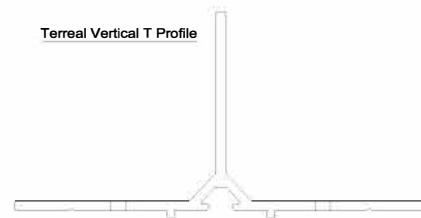

Terreal Vertical Gasket

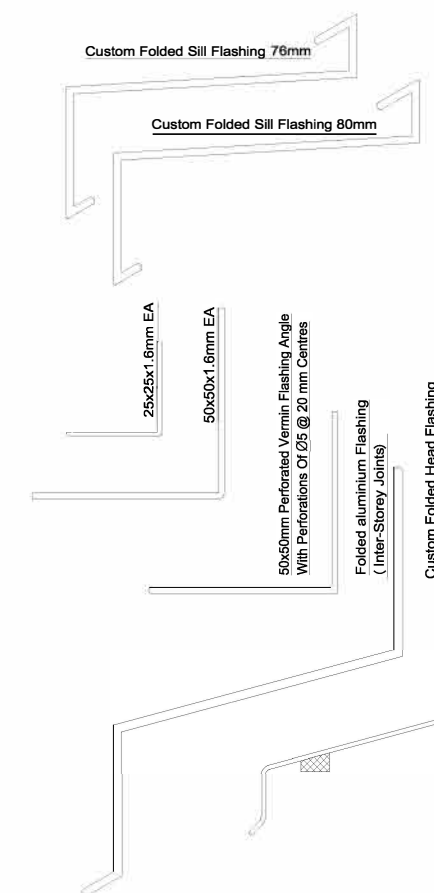
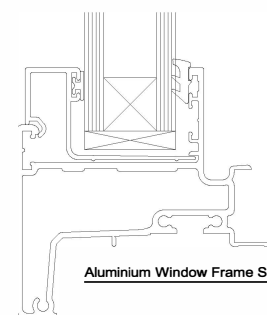
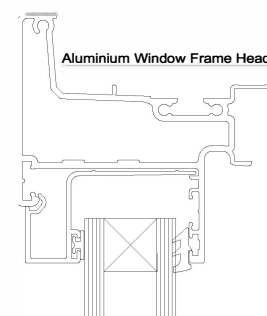
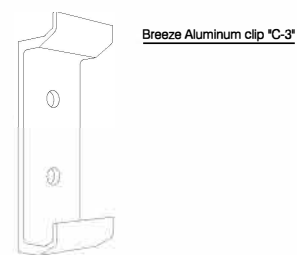

Notes / Spec:

**Breeze Tile
Accessory List**

Rev	Date	Notes	By
-----	------	-------	----



Copyright - ACM FABRICATORS LTD. No part of this document may be reproduced, stored in a retrieval system or transmitted in any form or by any means without prior permission in writing of ACM FABRICATORS LTD. All discrepancies shall be referred to ACM FABRICATORS LTD immediately.

Dwg Title:
Terreal Breeze Accessory List

Rev By: EK Chkd: Date: 21.11.14
Scale at A3: 1:2
CAD File: TERREAL BREEZE (DETAIL) R20190122.DWG
CAD Path: Terreal Breeze (Detail) R20190122.dwg



Dwg Revision:
20190122

Dwg No:
BREEZE ACC. LIST

Notes / Spec:

Terreal Breeze		
Label	Tolerance in mm	Dimension
A	±1.0	594
B	±1.5	304
C	±1.5	239
H	±0.5	35.5
Q	±0.5	29
TH	±1.0	16

Label	Tolerance in mm	
T	± 0.5	Squareness
U	± 2	Straightness of the top edge
X	± 2	Flatness over the height
W	± 2	Flatness over the length
V,D,Z ,Y	± 3	Sail effect at 4th point (3 fix points)

	Flatness
	Perpendicularity

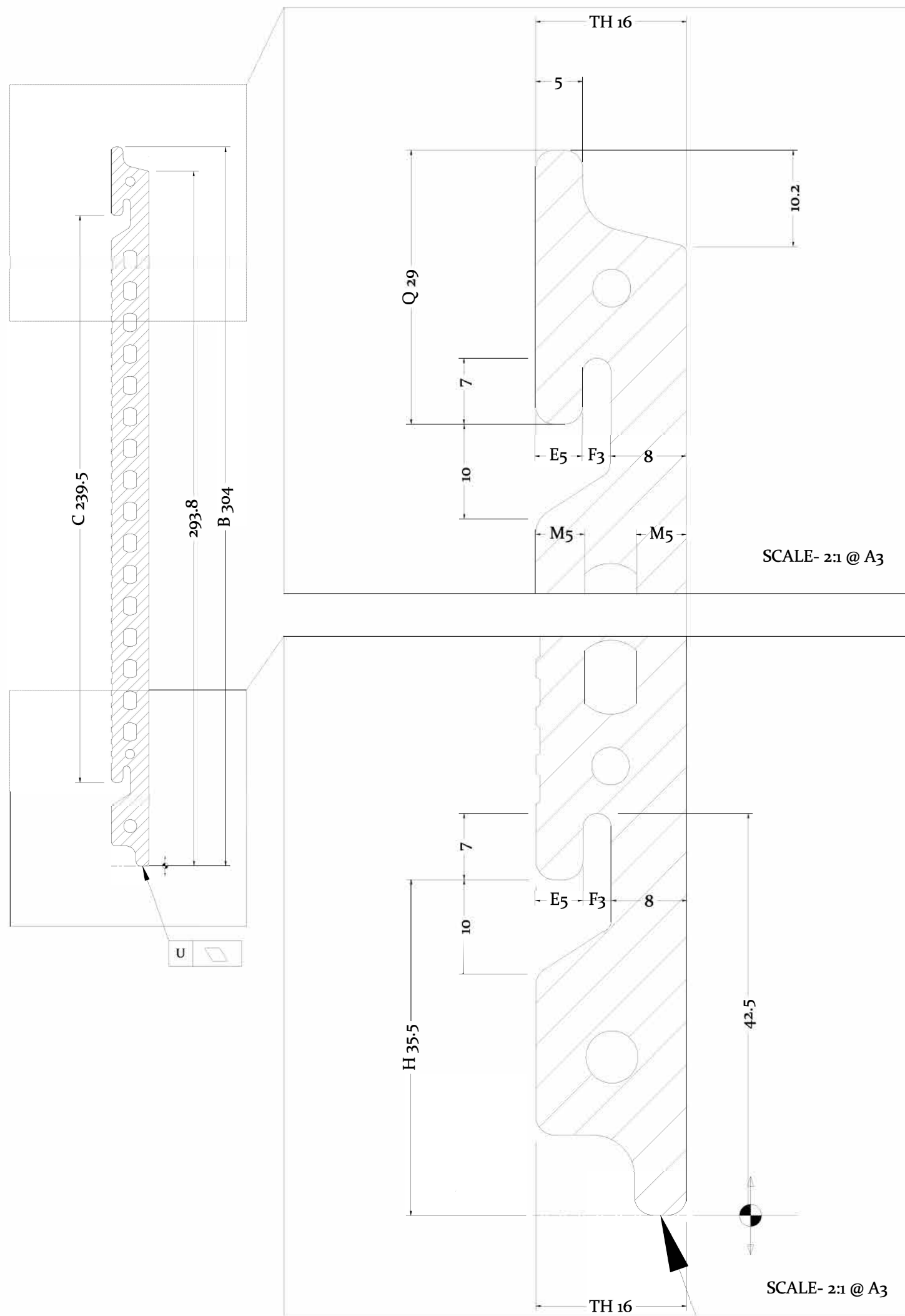

1 Breeze Tile Vital Stats.
01-01 201 Section 1:2 @ A3

Rev	Date	Notes	By

ACMF ACM Fabricators Ltd
PO BOX 101 760
NORTH SHORE 0745
4/54 ELLICE ROAD
GLENFIELD

Copyright - ACM FABRICATORS LTD. No part of this document may be reproduced, stored in a retrieval system in any form or transmitted by any means without prior permission in writing of ACM FABRICATORS LTD. All discrepancies shall be referred to ACM FABRICATORS LTD immediately.

Dwg Title:
Terreal Breeze Tile

Rev By: EK Chkd: Date: 21.11.14
Scale at A3: As Labeled
CAD File: TERREAL BREEZE (DETAIL) R20190122.DWG
CAD Path: Terreal Breeze [Detail] R20190122.dwg

Dwg Revision:
20190122

Dwg No:
01-01 201

1
01-01 202

Breeze C-3 Support Clip Vital Stats. Plan

1:2 @ A3

Regular clip

Material : 6060 T6

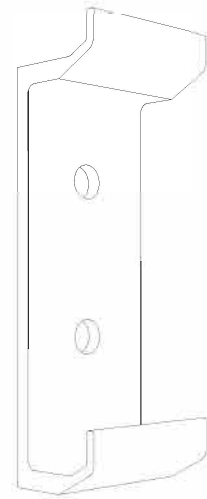

Top Termination
Clip

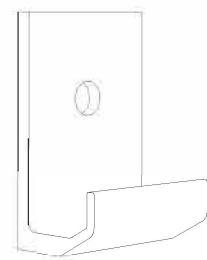

Using Regular clip Excision

Bottom Starting Clip

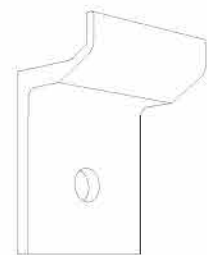

Using Regular clip Excision

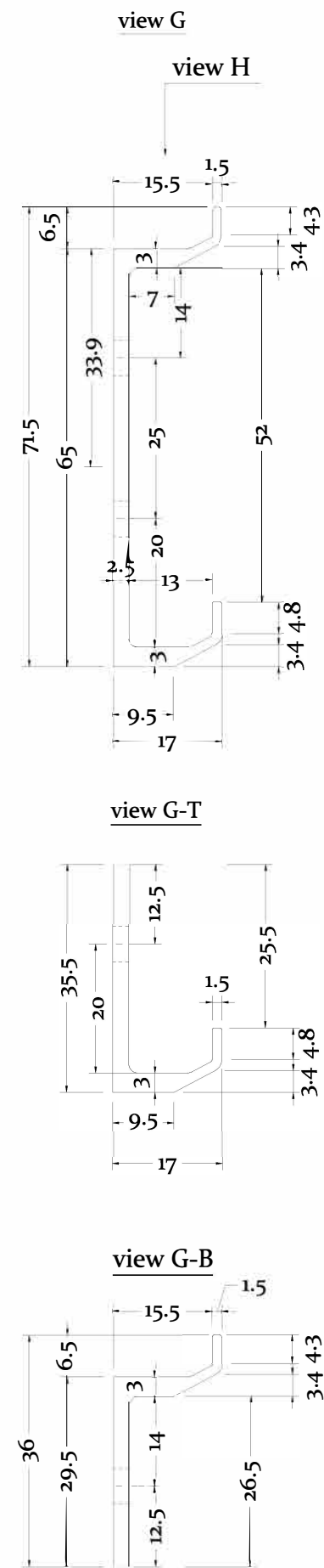
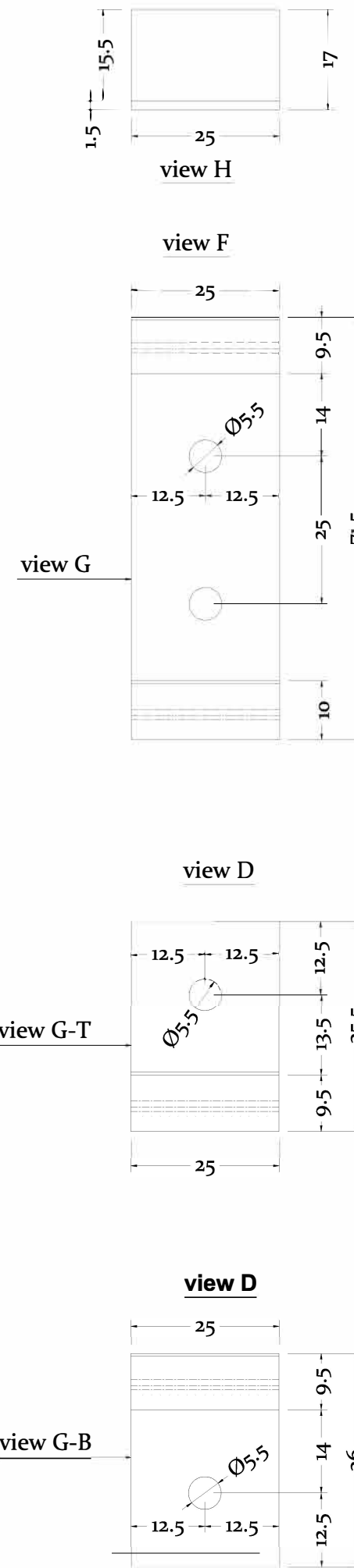

Rev	Date	Notes	By



Copyright - ACM FABRICATORS LTD. No part of this document may be reproduced, stored in a retrieval system in any form or transmitted by any means without prior permission in writing of ACM FABRICATORS LTD. All discrepancies shall be referred to ACM FABRICATORS LTD immediately.

Dwg Title:
Terreal Breeze Support C-3 Clip

Rev By: EK Chkd: Date: 21.11.14
Scale at A3: 1:1
CAD File: TERREAL BREEZE [DETAIL] R20190122.DWG
CAD Path: Terreal Breeze [Detail] R20190122.dwg

Dwg Revision:
20190122

Dwg No:
01-01 202

Notes / Spec:

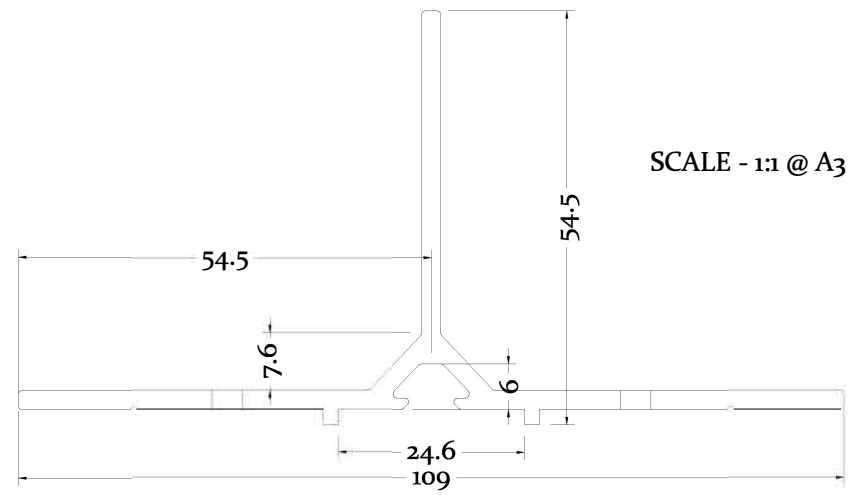

SCALE - 1:1 @ A3

Material : 6060 T6
 MASS : 1.1408 KG/ml

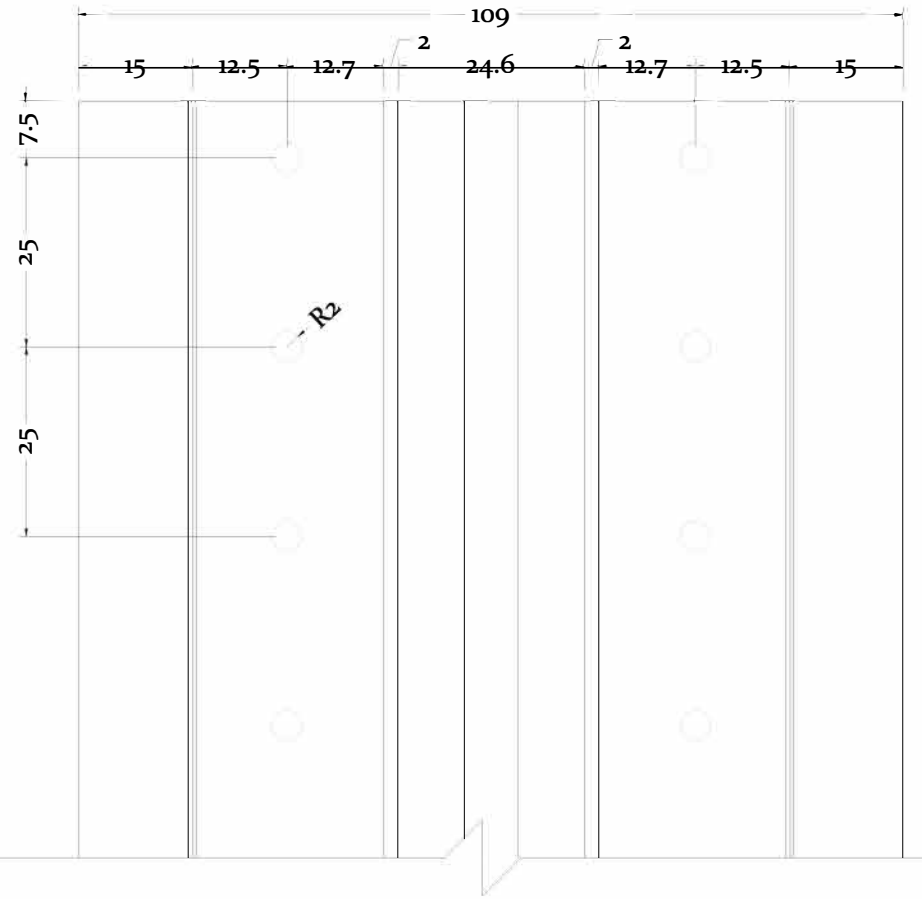

SCALE - 1:1 @ A3

1 Terreal Vertical Rail Vital Stats.
 01-01 203 Details As Labeled

support profile + Joints EPDM-BR-E6

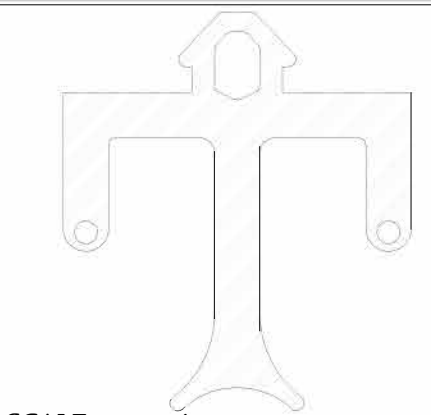
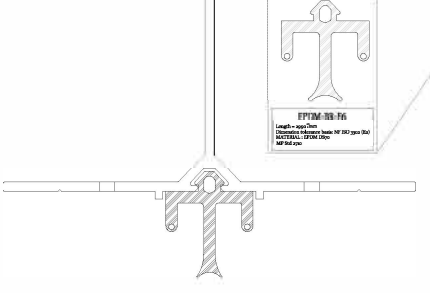

SCALE - 2:1 @ A3
EPDM-BR-E6
 Length = 2990 ±mm
 Dimension tolerance basis: NF ISO 3302 (E2)
 MATERIAL : EPDM DS70
 MP Std 2710

Profile T-3c + Joints EPDM-BR-E6

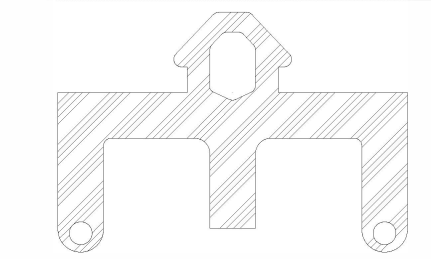
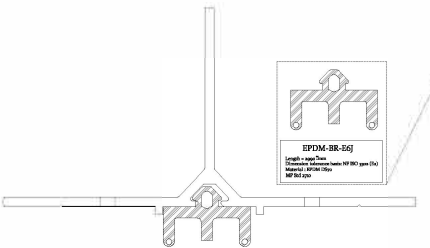

SCALE - 2:1 @ A3
EPDM-BR-E6J
 Length = 2990 ±mm
 Dimension tolerance basis: NF ISO 3302 (E2)
 Material : EPDM DS70
 MP Std 2710

Profile T-3c+ Joints cutting to centered EPDM-BR-E6
 SCALE - 1:2 @ A3

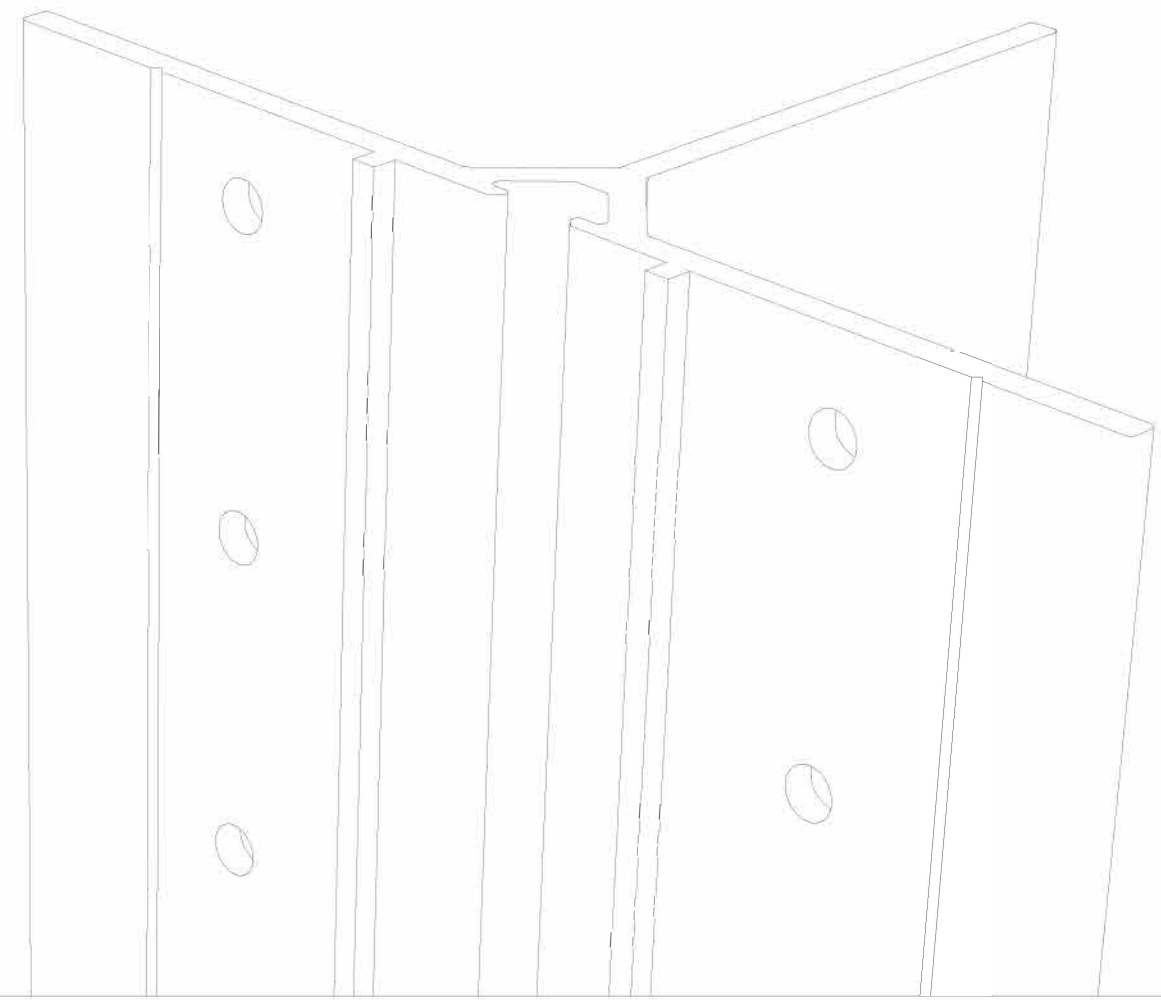

Rev	Date	Notes	By

ACMF
 ACM Fabricators Ltd
 PO BOX 101 760
 NORTH SHORE 0745
 4/54 ELLICE ROAD
 GLENFIELD

Copyright - ACM FABRICATORS LTD. No part of this document may be reproduced, stored in a retrieval system in any form or transmitted by any means without prior permission in writing of ACM FABRICATORS LTD. All discrepancies shall be referred to ACM FABRICATORS LTD immediately.

Dwg Title:
Terreal Vertical Rail

Rev By: EK Chkd: Date: 21.11.14
 Scale at A3: As Noted
 CAD File: TERREAL BREEZE (DETAIL) R20190122.DWG
 CAD Path: Terreal Breeze (Detail) R20190122.dwg

Dwg Revision:
20190122

Dwg No:
01-01 203

Notes / Spec:

- 1. TIMBER FRAMING
- 2a. RIGID WALL UNDERLAY, FIBRE CEMENT SHEET 6MM
- 2b. BUILDING MEMBRANE
- 3. TESCON NAIDEC BUTYL STRIP
- 4. BRACKET T50 BR
- 4a. SELF-DRILLING HEX HEAD SCREW CLASS 4 HDG 12g x 22 mm
- 5. VERTICAL ALUMINUM SUPPORT T50 VR
- 5a. SELF-DRILLING SS PH 6g X 12 MM
- 8b. TERREAL BREEZE TERRA COTTA TILE, 16MM DOUBLE WALL
- 9. 14g X 75 mm TIMBER TEK SCREW CLASS 4 HDG / 1 PER BRACKET
- 12a. ALUMINUM Window JOINERY
- 13. T50 CL ALUMINUM CLIP PROFILE
- 14. T50 JC ALUMINUM JAMB CLOSER
- 16. BREEZE C-3 SUPPORT CLIP

-NOTE:
ACM FABRICATORS LTD T50 CLADDING SUPPORT SYSTEM INSTALLATION MANUAL MUST BE FOLLOWED AT ALL TIMES.
01-06 T50 Installation Manual Rev. 20150501

-NOTE:
FOR WRAP FIXING REFER TO SPECIFIED MANUFACTURER INSTALLATION MANUAL

Rev	Date	Notes	By



ACM Fabricators Ltd
PO BOX 101 760
NORTH SHORE 0745
4/54 ELLICE ROAD
GLENFIELD

Copyright - ACM FABRICATORS LTD. No part of this document may be reproduced, stored in a retrieval system in any form or transmitted by any means without prior permission in writing of ACM FABRICATORS LTD. All discrepancies shall be referred to ACM FABRICATORS LTD immediately.

Dwg Title:
Breeze + SFA

Rev By: EK Chkd: Date: 21.11.14
Scale at A3: 1:2
CAD File: TERREAL BREEZE (DETAIL) R20190122.DWG
CAD Path: Terreal Breeze (Detail) R20190122.dwg

Dwg Revision:
20190122

Dwg No:
01-01 204

1
01-01 204

Internal Corner Plan

1:2 @ A3

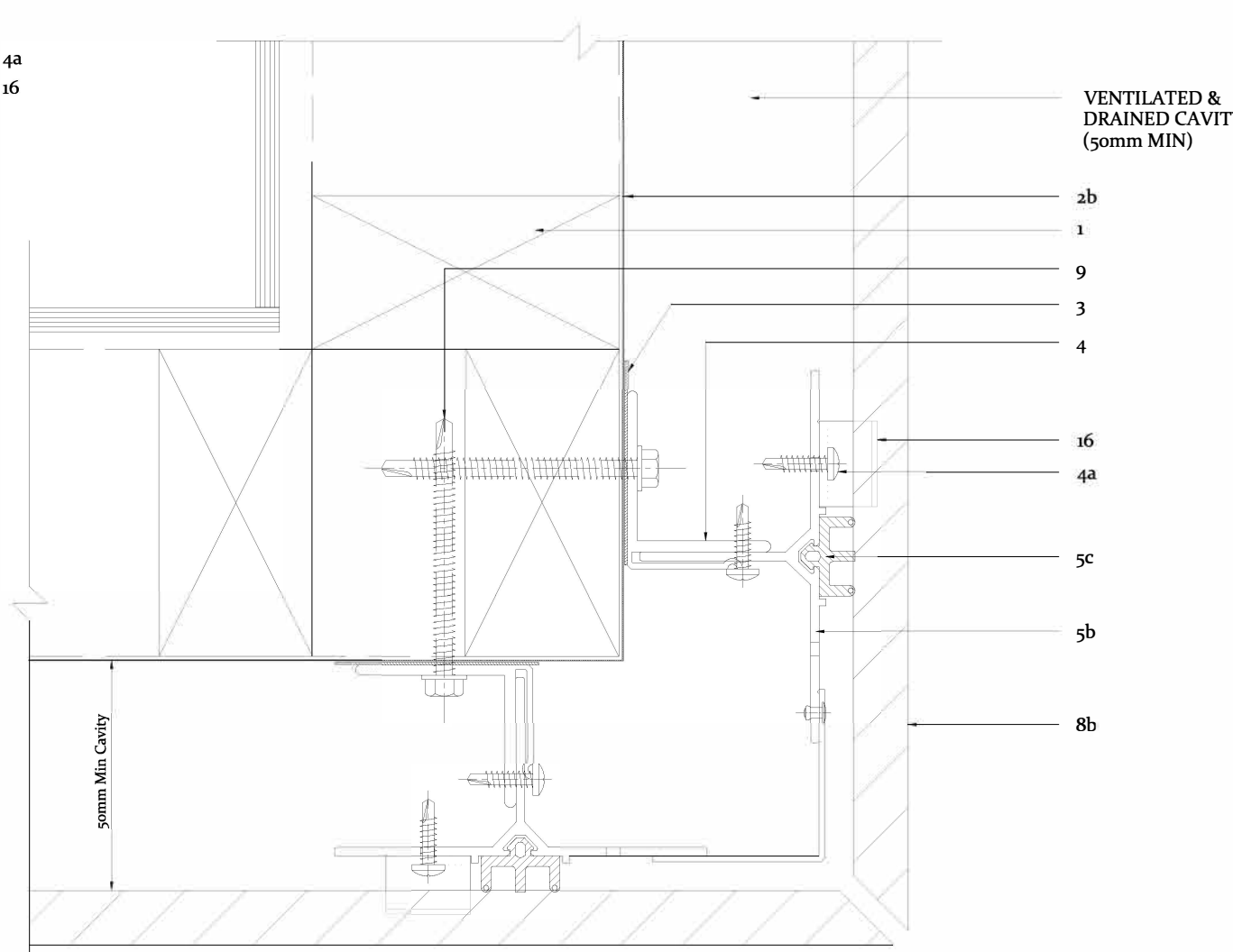
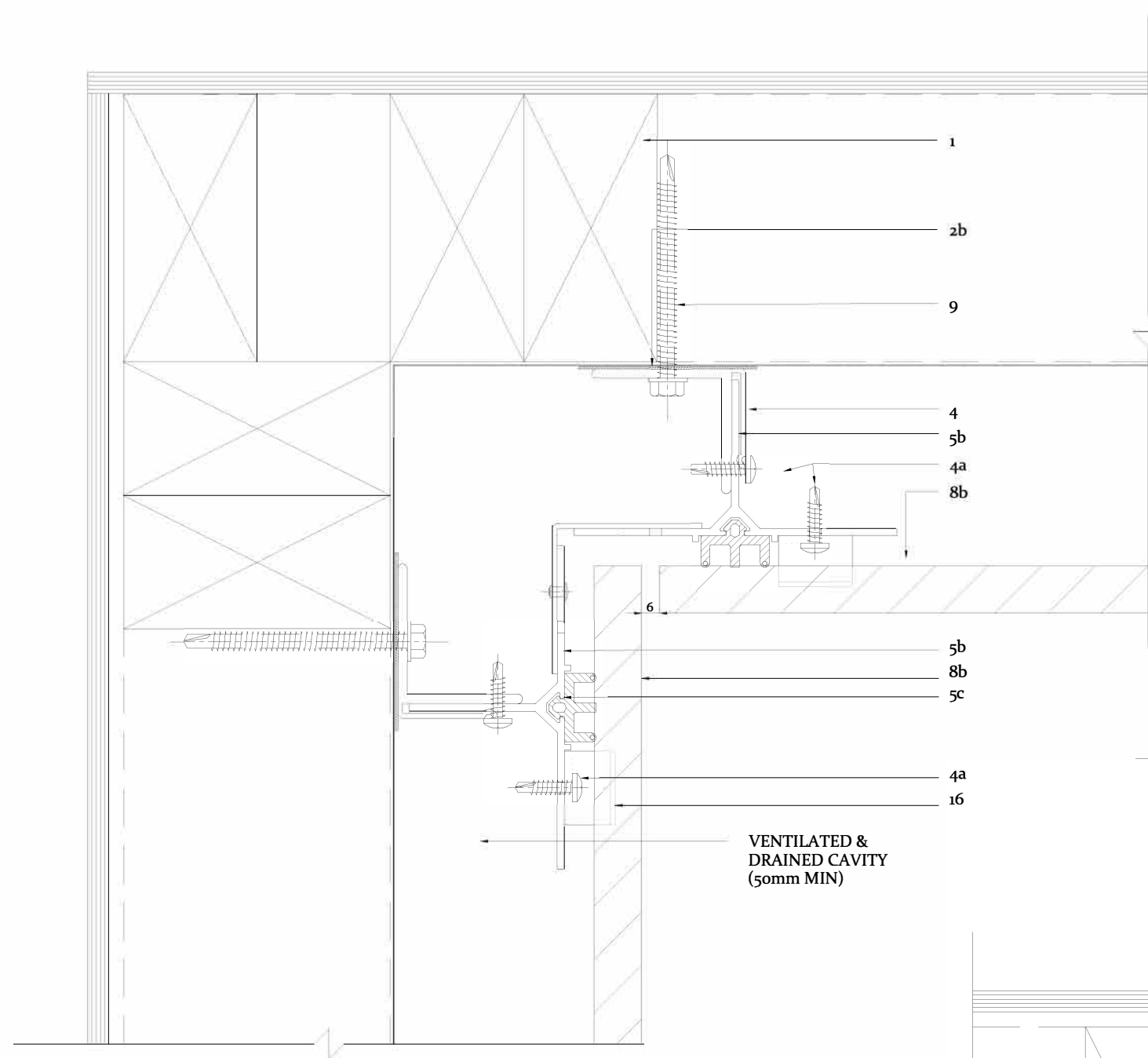

2
01-01 204

External Corner Plan

1:2 @ A3

1 Negative Detail
01-01 205 1:2 @ A3

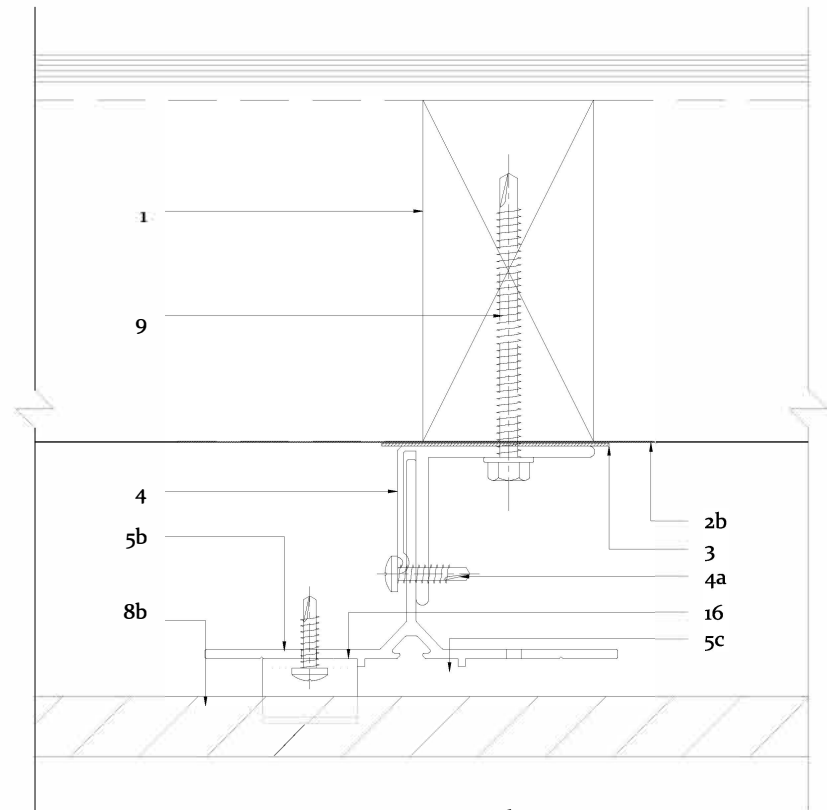
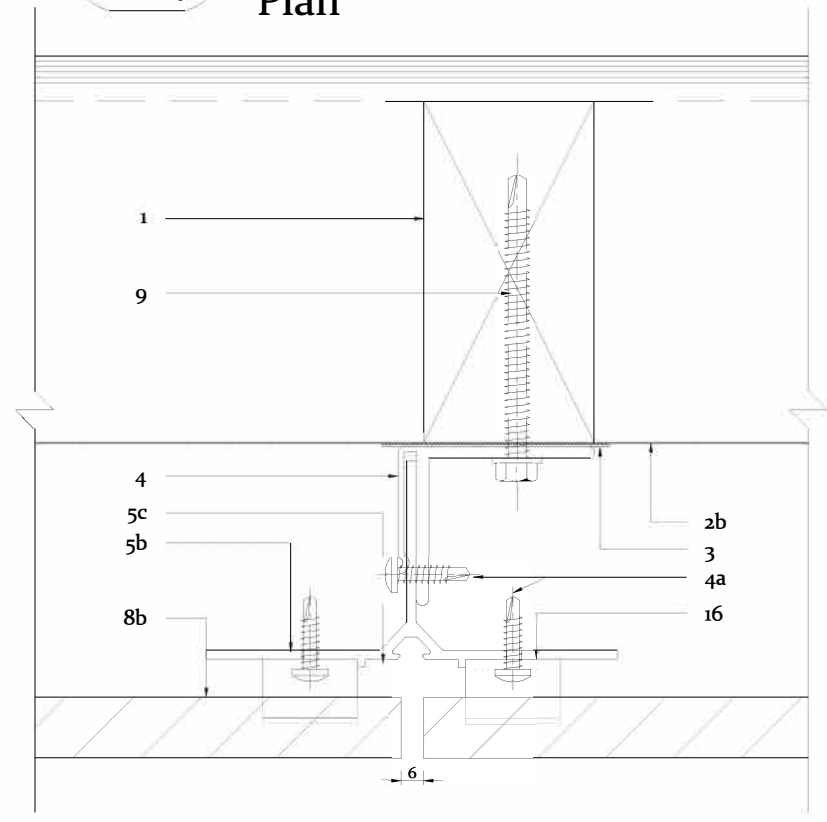

2 Intermediate Support
01-01 205 1:2 @ A3

3 Window Head Detail
01-01 205 1:2 @ A3

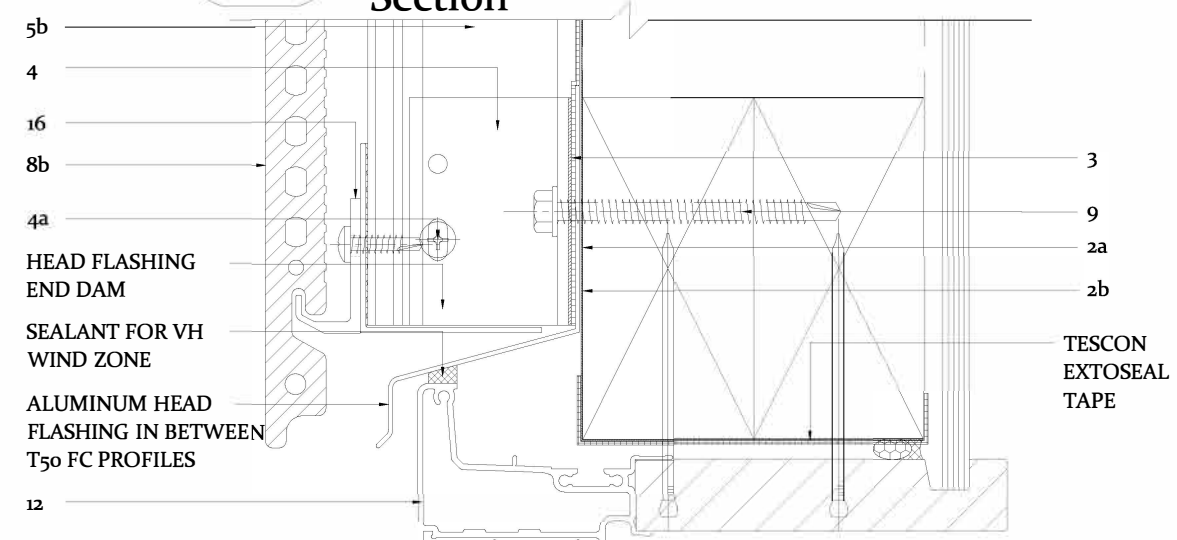

8g SS SCREWS @ 450mm ctrs;
HEADS OVERSEALED

DASHED LINE SHOWS LINE
OF SILL FLASHING END DAM

END CAP FIXED TO SILL TRAY END DAM
WITH NO.5 POP RIVETS OVERSEALED

2mm FOLDED ALUMINIUM FLASHING;
ALUMINIUM SOAKER AT JOINTS;
JOINTS TO ALIGN WITH TERRACOTTA
JOINTS BELOW

CONTINUOUS 1.6mm ALUMINIUM ANGLE
BEDSEALED AND FIXED WITH 8g SS
SCREWS @450mm ctrs;
HEADS OVERSEALED

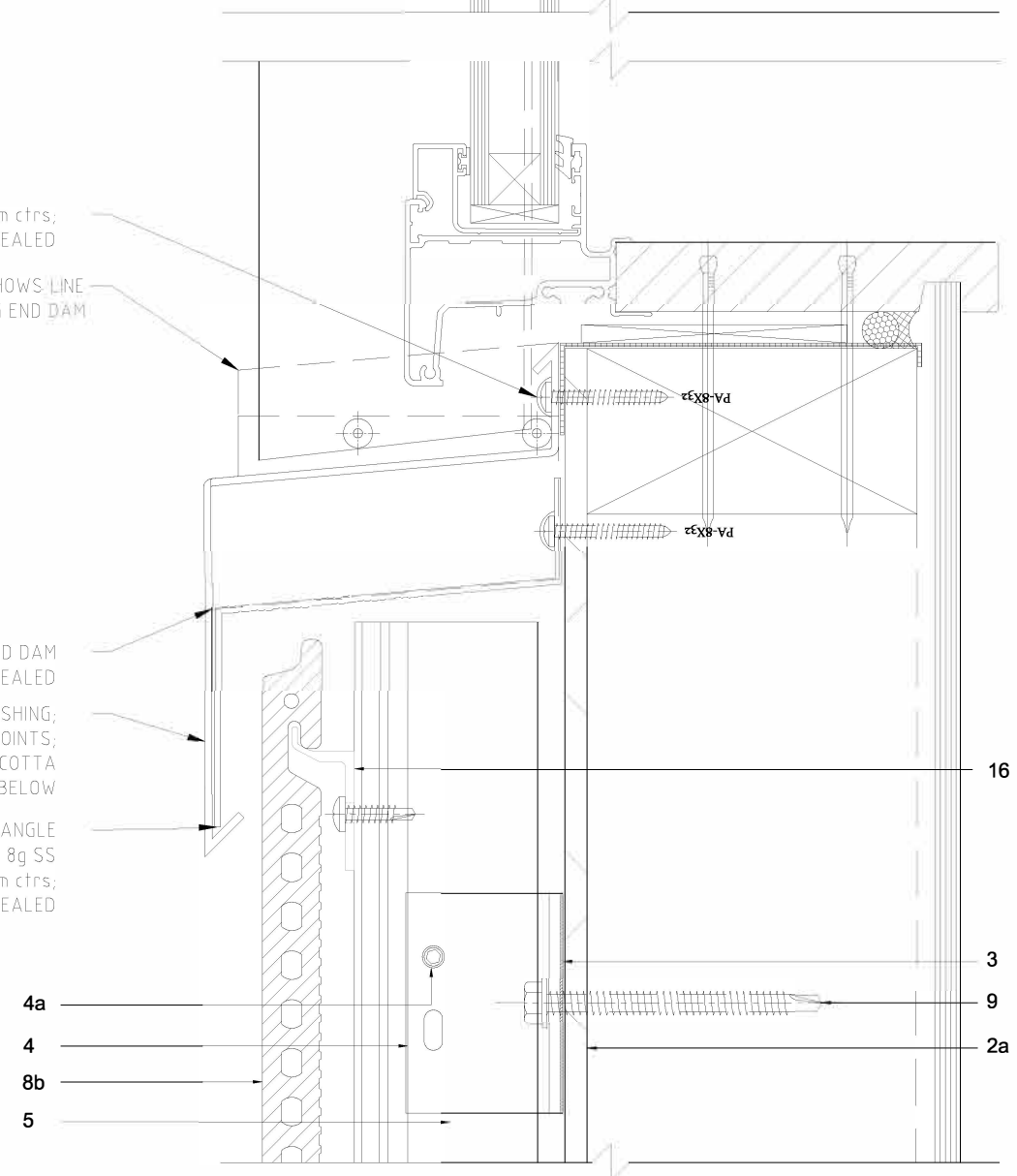

4 Window Sill Detail
01-01 205 1:2 @ A3

- Notes / Spec:**
1. TIMBER FRAMING
 - 2a. RIGID WALL UNDERLAY, FIBRE CEMENT SHEET 6MM
 - 2b. BUILDING MEMBRANE
 3. TESCON NAIDEC BUTYL STRIP
 4. BRACKET T50 BR
 - 4a. SELF-DRILLING HEX HEAD SCREW CLASS 4 HDG 12g x 22 mm
 5. VERTICAL ALUMINUM SUPPORT T50 VR
 - 5a. SELF-DRILLING SS PH 6g X 12 MM
 - 8b. TERREAL BREEZE TERRA COTTA TILE, 16MM DOUBLE WALL
 9. 14g X 75 mm TIMBER TEK SCREW CLASS 4 HDG / 1 PER BRACKET
 - 12a. ALUMINUM Window JOINERY
 13. T50 CL ALUMINUM CLIP PROFILE
 14. T50 JC ALUMINUM JAMB CLOSER
 16. BREEZE C-3 SUPPORT CLIP

-NOTE:
ACM FABRICATORS LTD T50 CLADDING
SUPPORT SYSTEM INSTALLATION MANUAL
MUST BE FOLLOWED AT ALL TIMES.
01-06 T50 Installation Manual Rev. 20150501

-NOTE:
FOR WRAP FIXING REFER TO SPECIFIED
MANUFACTURER INSTALLATION MANUAL

Rev	Date	Notes	By

ACMF ACM Fabricators Ltd
PO BOX 101 760
NORTH SHORE 0745
4/54 ELLICE ROAD
GLENFIELD

Copyright - ACM FABRICATORS LTD. No part of this document may be reproduced, stored in a retrieval system in any form or transmitted by any means without prior permission in writing of ACM FABRICATORS LTD. All discrepancies shall be referred to ACM FABRICATORS LTD immediately.

Dwg Title:
Breeze + SFA

Rev By: EK Chkd: Date: 21.11.14
Scale at A3: 1:2
CAD File: TERREAL BREEZE [DETAIL] R20190122.DWG
CAD Path: Terreal Breeze [Detail] R20190122.dwg

Dwg Revision:
20190122

Dwg No:
01-01 205

Soffit Detail

1
01-01 206

Plan Section

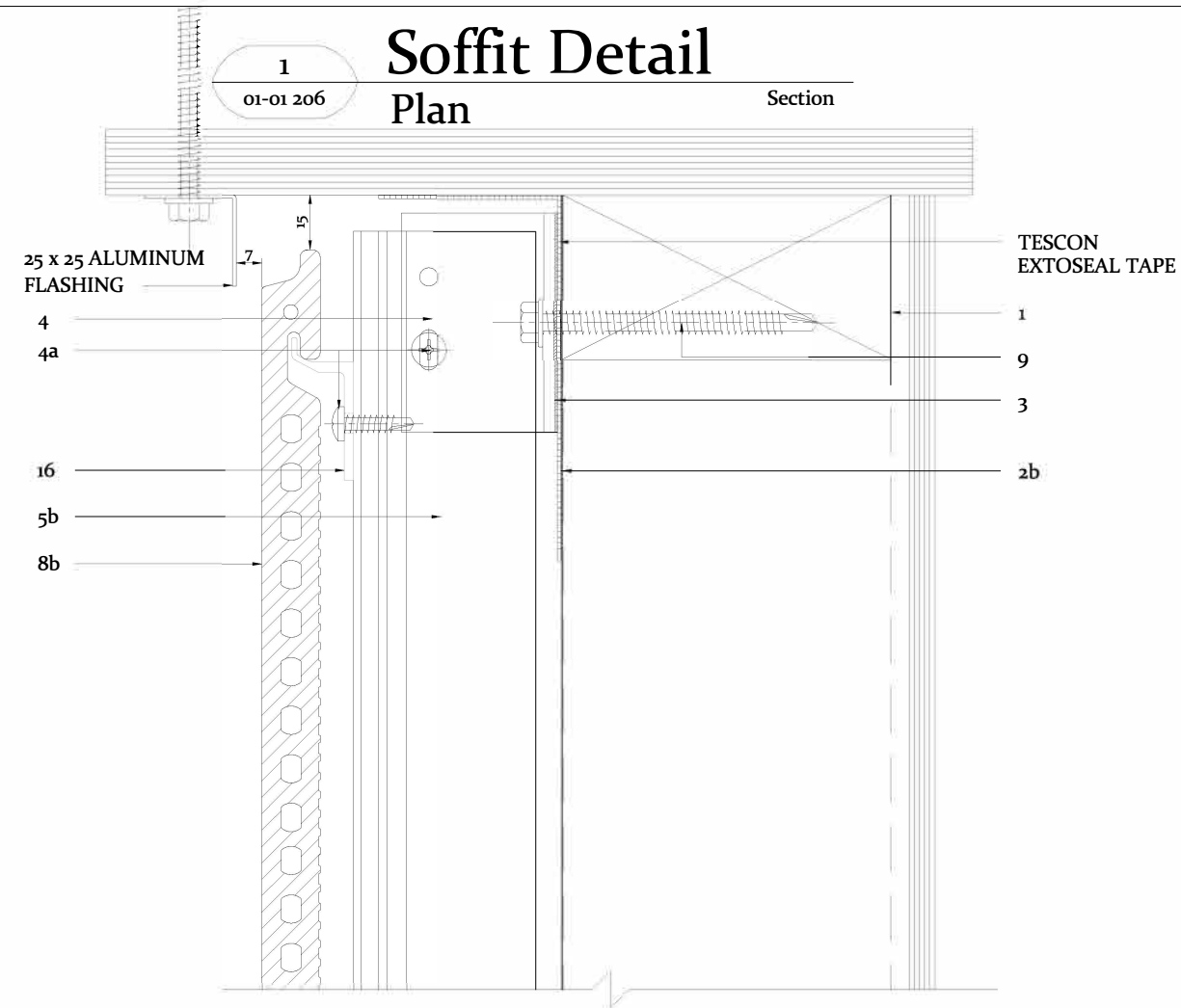

Inter-Storey Detail

2
01-01 206

Section 1:2 @ A3

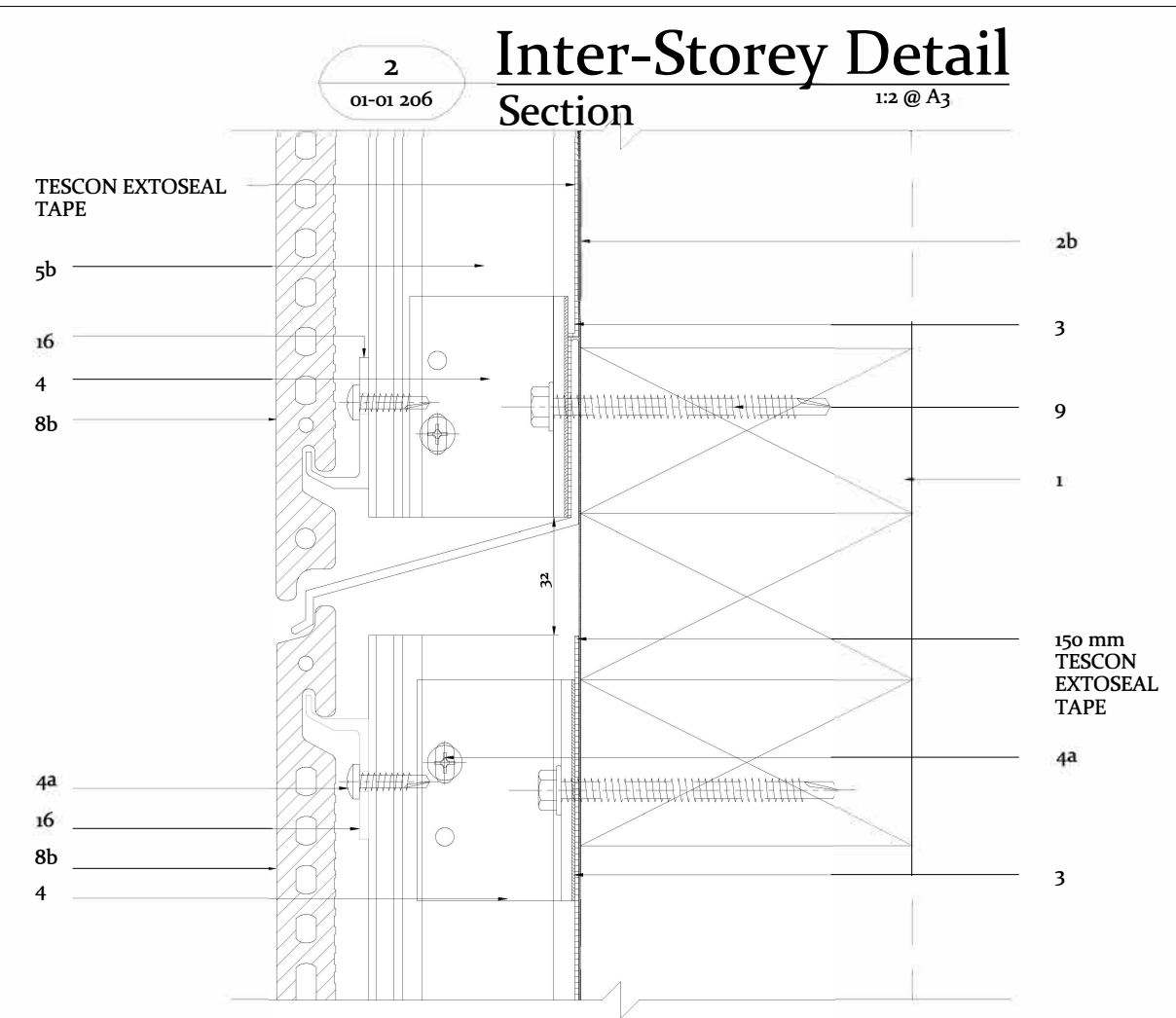

Horizontal Joint Detail

2
01-01 206

Section 1:2 @ A3

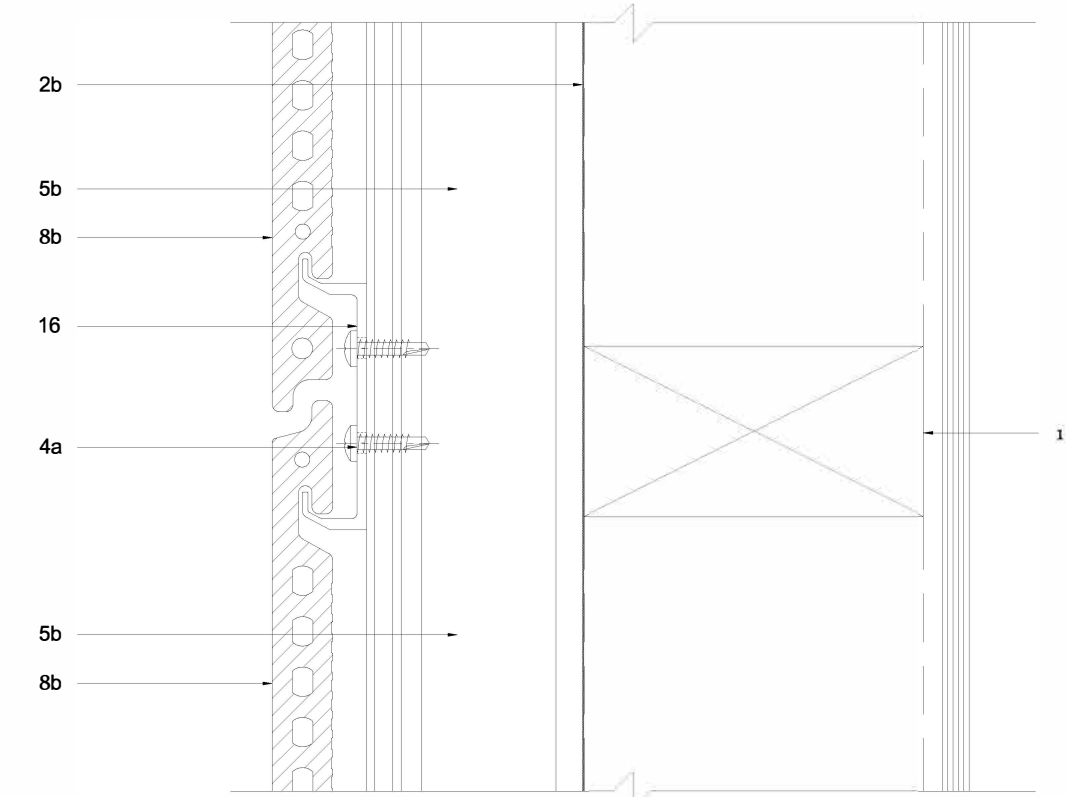

Bottom of Cladding

4
01-01 206

Section 1:2 @ A3

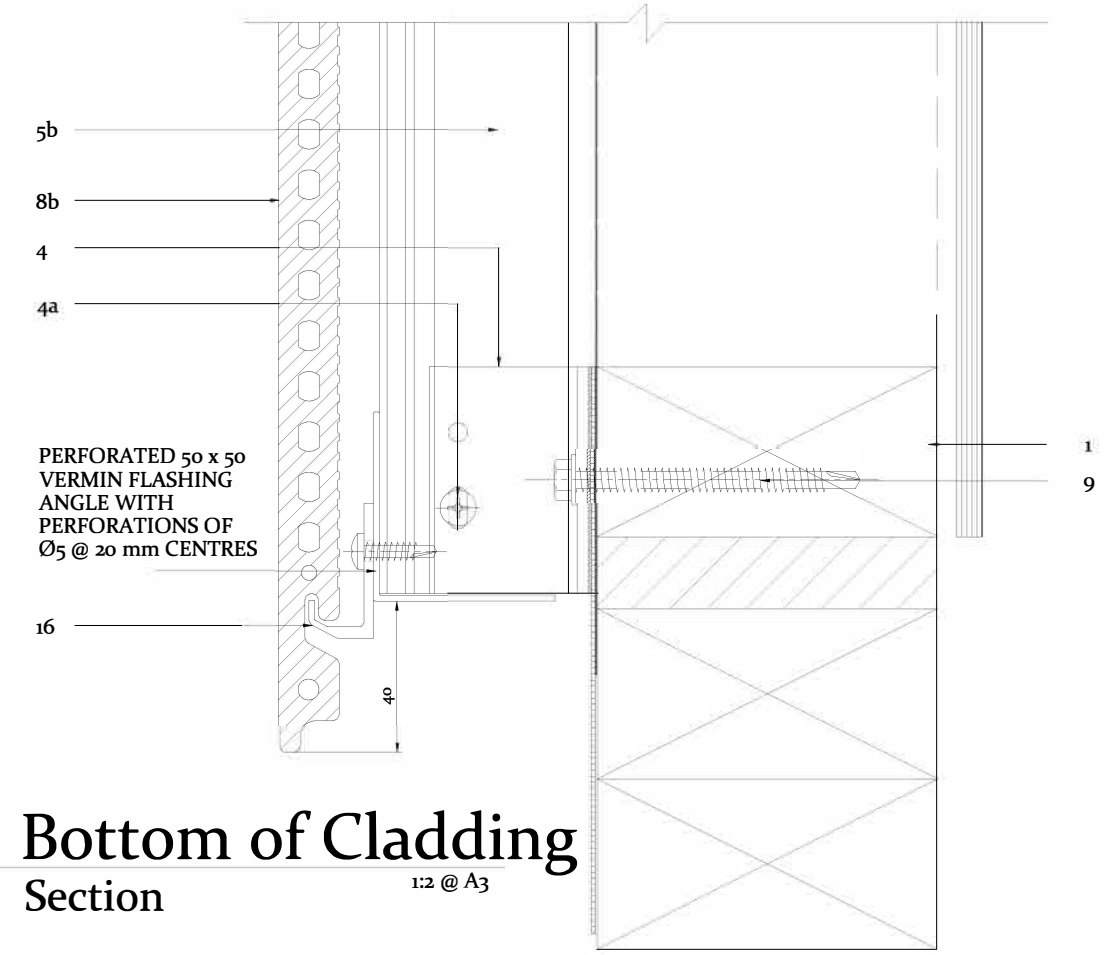

- Notes / Spec:**
1. TIMBER FRAMING
 - 2a. RIGID WALL UNDERLAY, FIBRE CEMENT SHEET 6MM
 - 2b. BUILDING MEMBRANE
 3. TESCON NAIDEC BUTYL STRIP
 4. BRACKET T50 BR
 - 4a. SELF-DRILLING HEX HEAD SCREW CLASS 4 HDG 12g x 22 mm
 5. VERTICAL ALUMINUM SUPPORT T50 VR
 - 5a. SELF-DRILLING SS PH 6g X 12 MM
 - 8b. TERREAL BREEZE TERRA COTTA TILE, 16MM DOUBLE WALL
 9. 14g X 75 mm TIMBER TEK SCREW CLASS 4 HDG / 1 PER BRACKET
 - 12a. ALUMINUM Window JOINERY
 13. T50 CL ALUMINUM CLIP PROFILE
 14. T50 JC ALUMINUM JAMB CLOSER
 16. BREEZE C-3 SUPPORT CLIP

-NOTE:
ACM FABRICATORS LTD T50 CLADDING SUPPORT SYSTEM INSTALLATION MANUAL MUST BE FOLLOWED AT ALL TIMES.
01-06 T50 Installation Manual Rev. 20150501

-NOTE:
FOR WRAP FIXING REFER TO SPECIFIED MANUFACTURER INSTALLATION MANUAL

Rev	Date	Notes	By

ACMF ACM Fabricators Ltd
PO BOX 101 760
NORTH SHORE 0745
4/54 ELLICE ROAD
GLENFIELD

Copyright - ACM FABRICATORS LTD. No part of this document may be reproduced, stored in a retrieval system in any form or transmitted by any means without prior permission in writing of ACM FABRICATORS LTD. All discrepancies shall be referred to ACM FABRICATORS LTD immediately.

Dwg Title:
Breeze + SFA

Rev By: EK Chkd: Date: 21.11.14
Scale at A3: 1:2
CAD File: TERREAL BREEZE [DETAIL] R20190122.DWG
CAD Path: Terreal Breeze [Detail] R20190122.dwg

Dwg Revision:
20190122

Dwg No:
01-01 206

Notes / Spec:

- 1. TIMBER FRAMING
- 2a. RIGID WALL UNDERLAY, FIBRE CEMENT SHEET 6MM
- 2b. BUILDING MEMBRANE
- 3. TESCON NAIDEC BUTYL STRIP
- 4. BRACKET T50 BR
- 4a. SELF-DRILLING HEX HEAD SCREW CLASS 4 HDG 12g x 22 mm
- 5. VERTICAL ALUMINUM SUPPORT T50 VR
- 5a. SELF-DRILLING SS PH 6g X 12 MM
- 8b. TERREAL BREEZE TERRA COTTA TILE, 16MM DOUBLE WALL
- 9. 14g X 75 mm TIMBER TEK SCREW CLASS 4 HDG / 1 PER BRACKET
- 12a. ALUMINUM Window JOINERY
- 13. T50 CL ALUMINUM CLIP PROFILE
- 14. T50 JC ALUMINUM JAMB CLOSER
- 16. BREEZE C-3 SUPPORT CLIP

-NOTE:
ACM FABRICATORS LTD T50 CLADDING SUPPORT SYSTEM INSTALLATION MANUAL MUST BE FOLLOWED AT ALL TIMES.
01-06 T50 Installation Manual Rev. 20150501

-NOTE:
FOR WRAP FIXING REFER TO SPECIFIED MANUFACTURER INSTALLATION MANUAL

Rev	Date	Notes	By

ACMF ACM Fabricators Ltd
PO BOX 101 760
NORTH SHORE 0745
4/54 ELLICE ROAD
GLENFIELD

Copyright - ACM FABRICATORS LTD. No part of this document may be reproduced, stored in a retrieval system in any form or transmitted by any means without prior permission in writing of ACM FABRICATORS LTD. All discrepancies shall be referred to ACM FABRICATORS LTD immediately.

Dwg Title:
Breeze + SFA

Rev By: EK Chkd: Date: 21.11.14
Scale at A3: 1:2
CAD File: TERREAL BREEZE [DETAIL] R20190122.DWG
CAD Path: Terreal Breeze [Detail] R20190122.dwg

Dwg Revision:
20190122

Dwg No:
01-01 207

1
01-01 207

Building Connection Detail Plan

1:2 @ A3

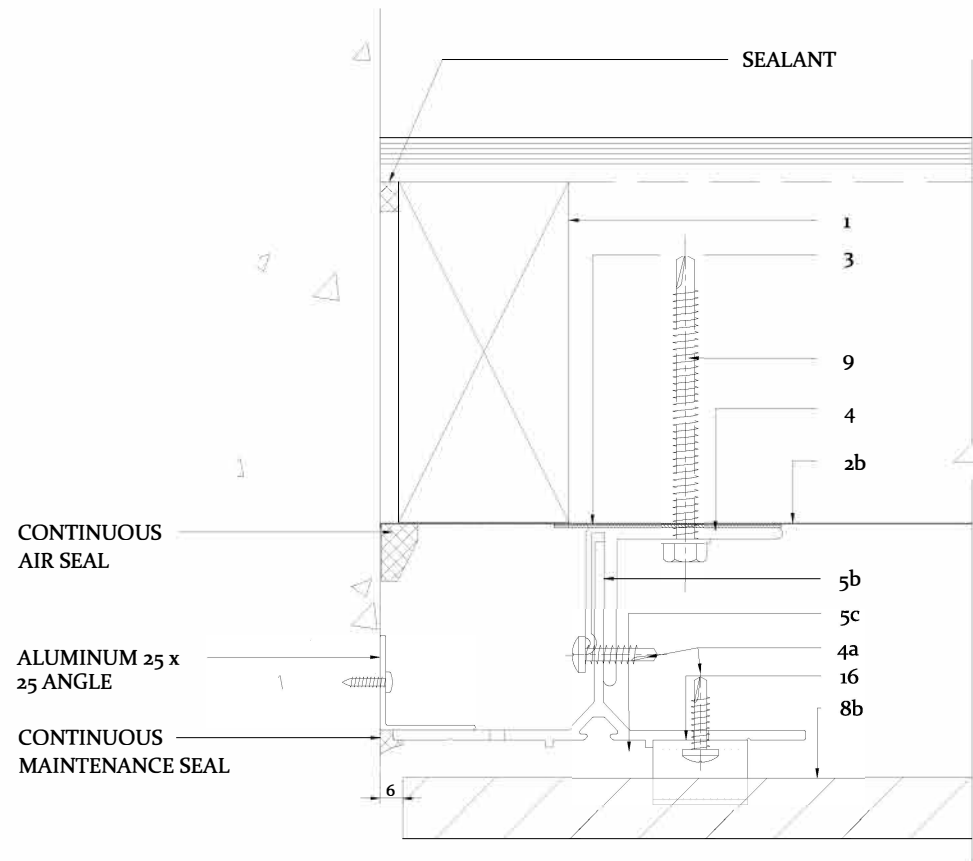

2
01-01 207

Jamb Closure Detail Plan

1:2 @ A3

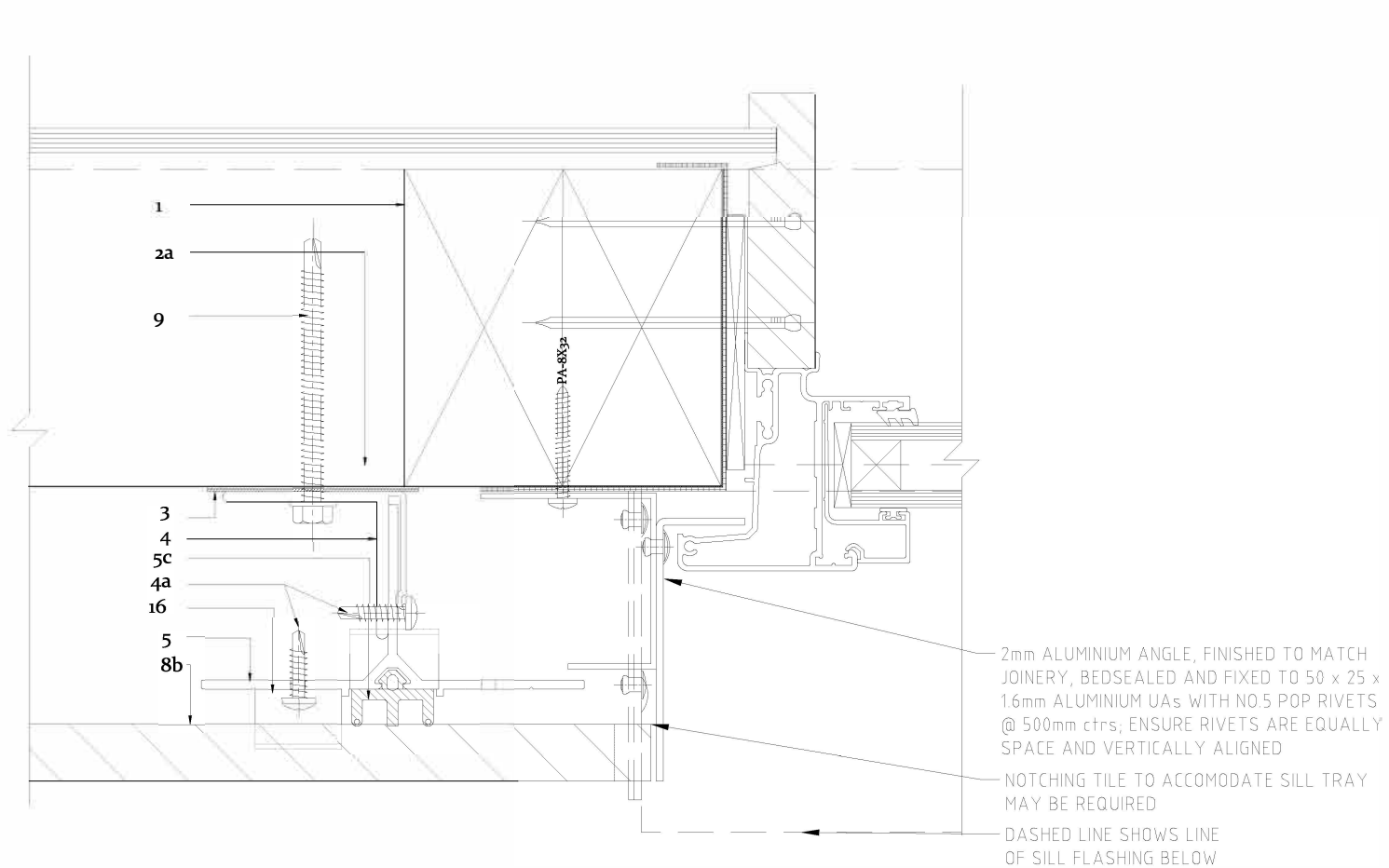

2mm ALUMINIUM ANGLE, FINISHED TO MATCH JOINERY, BEDSEALED AND FIXED TO 50 x 25 x 1.6mm ALUMINIUM UAs WITH NO.5 POP RIVETS @ 500mm ctrs; ENSURE RIVETS ARE EQUALLY SPACE AND VERTICALLY ALIGNED

NOTCHING TILE TO ACCOMODATE SILL TRAY MAY BE REQUIRED

DASHED LINE SHOWS LINE OF SILL FLASHING BELOW

Jamb Closure to Sill Tray Joint
 NTS
 3D - Flatshot

1
 01-01 208

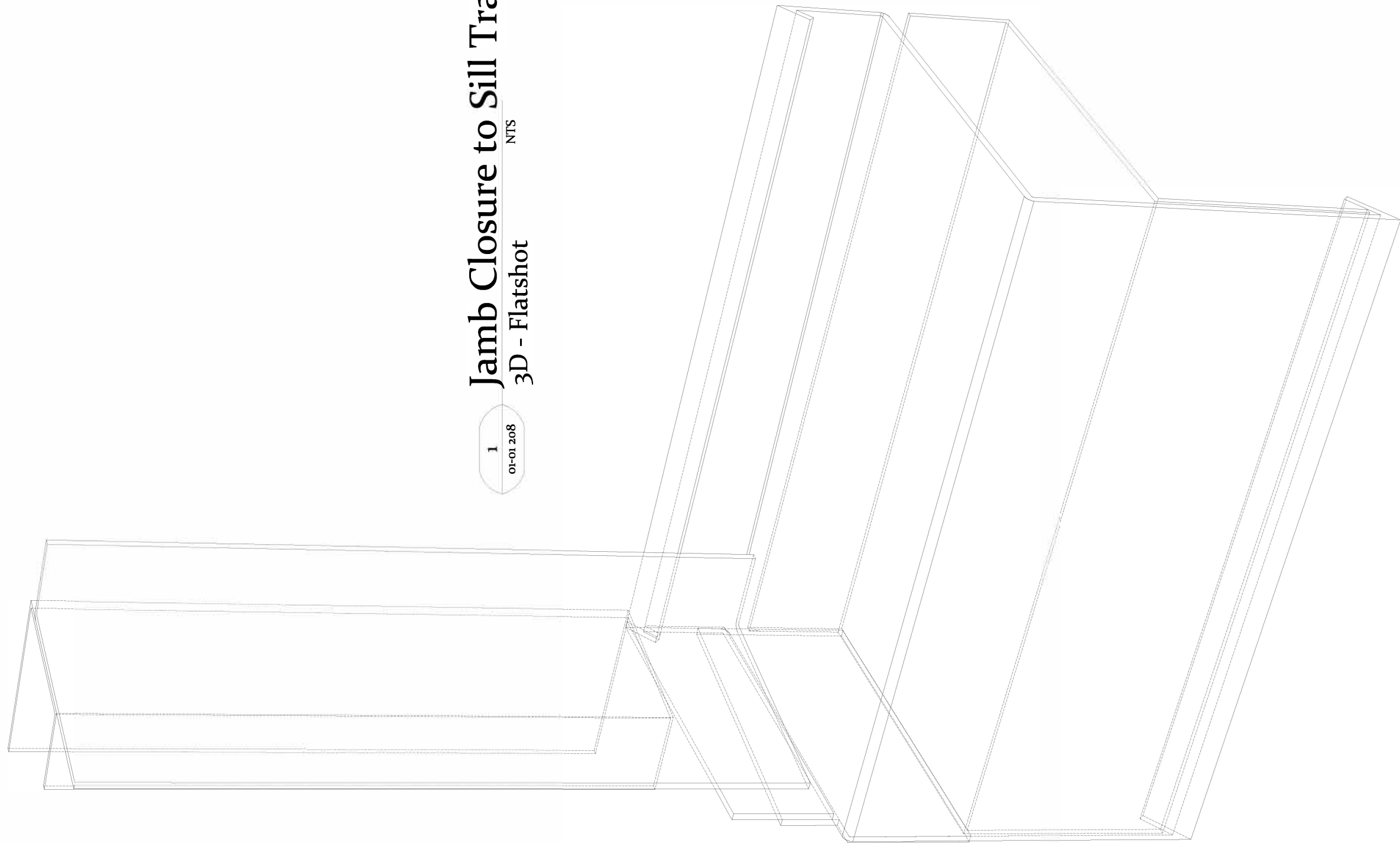

- Notes / Spec:**
- 1. TIMBER FRAMING
 - 2a. RIGID WALL UNDERLAY, FIBRE CEMENT SHEET 6MM
 - 2b. BUILDING MEMBRANE
 - 3. TESCON NAIDEC BUTYL STRIP
 - 4. BRACKET T50 BR
 - 4a. SELF-DRILLING HEX HEAD SCREW CLASS 4 HDG 12g x 22 mm
 - 5. VERTICAL ALUMINUM SUPPORT T50 VR
 - 5a. SELF-DRILLING SS PH 6g X 12 MM
 - 8b. TERREAL BREEZE TERRA COTTA TILE, 16MM DOUBLE WALL
 - 9. 14g X 75 mm TIMBER TEK SCREW CLASS 4 HDG / 1 PER BRACKET
 - 12a. ALUMINUM Window JOINERY
 - 13. T50 CL ALUMINUM CLIP PROFILE
 - 14. T50 JC ALUMINUM JAMB CLOSER
 - 16. BREEZE C-3 SUPPORT CLIP

-NOTE:
 ACMFABRICATORS LTD T50 CLADDING SUPPORT SYSTEM INSTALLATION MANUAL MUST BE FOLLOWED AT ALL TIMES.
 01-06 T50 Installation Manual Rev. 20150501

-NOTE:
 FOR WRAP FIXING REFER TO SPECIFIED MANUFACTURER INSTALLATION MANUAL

Rev	Date	Notes	By

ACMF ACM Fabricators Ltd
 PO BOX 101 760
 NORTH SHORE 0745
 4/54 ELLICE ROAD
 GLENFIELD

Copyright - ACM FABRICATORS LTD. No part of this document may be reproduced, stored in a retrieval system or transmitted by any means without prior permission in writing of ACM FABRICATORS LTD. All discrepancies shall be referred to ACM FABRICATORS LTD immediately.

Dwg Title:
Breeze + SFA

Rev By: EK Chkd: Date: 21.11.14
 Scale at A3: 1:2
 CAD File: TERREAL BREEZE [DETAIL] R20190122.DWG
 CAD Path: Terreal Breeze [Detail] R20190122.dwg

Dwg Revision:
20190122

Dwg No:
01-01 208